



ST. ANNE'S COLLEGE OF ENGINEERING AND TECHNOLOGY
(Approved by AICTE, New Delhi. Affiliated to Anna University, Chennai)
ANGUCHETTYPALAYAM, PANRUTI – 607 106.

DEPARTMENT OF ELECTRICAL AND ELECTRONICS ENGINEERING

EE 3591 - POWER ELECTRONICS

V SEMESTER

Prepared by

Mrs. T. ARTHI, AP/EEE

UNIT-I

SWITCHING POWER SUPPLIES

DYNAMIC BEHAVIOR OF MOSFET:

Power MOSFET is an enhancement mode device modified to handle much large currents and voltages than a conventional MOSFET. Prior to the invention of the power MOSFETs, MOSFETs could not compete with the power ratings of larger BJTs. But now the power MOSFETs are better than the power BJTs in many applications requiring high load power.

One main advantage of power MOSFETs is that they are inherently temperature stable and cannot go into thermal runaway. Another advantage of power MOSFETs is that they can be operated in parallel while power BJTs cannot.

In addition to above, Switching Characteristics of Power MOSFET have the advantage of switching a large current off faster than a BJTs can because a power MOSFET does not have minority carriers. They are 10 to 100 times faster than with comparable BJTs.

During cut-off the gate-to-source v_{gs} is less than threshold value. To turn on, v_{gs} is to be increased to well above the threshold value. The drain-to-source voltage must be less than $v_{gs} - V_{GST}$. The Switching Characteristics of Power MOSFET are influenced to a large extent by the internal capacitances of the device and the internal impedance of the gate drive circuit.

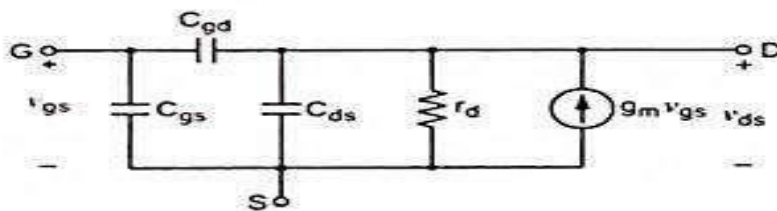

(a) Switching Model of MOSFETs

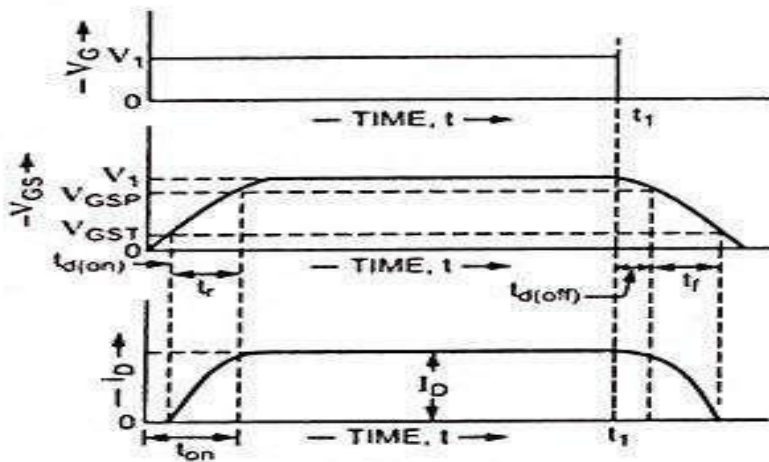

(b) Switching waveforms

Fig. 31.15

The Switching Characteristics of Power MOSFET is shown in Fig. 31.15(a). The three internal capacitances are gate-to-source capacitance C_{gs} , gate-to-drain capacitance C_{gd} and drain-to-source C_{gd} . During turning on C_{gd} and C_{gs} are to be charged through gate. This charging takes a finite time. So, the turn on cannot be instantaneous. Moreover, these capacitances are nonlinear and are not constant but dependent on dc bias voltage.

The typical switching waveforms of Power MOSFETs are shown in Fig. 31.15(b).

The **turn-on delay** $t_{d(on)}$ is the time that is required to charge the input capacitance to threshold voltage level. The **rise time** t_r is the gate charging time from the threshold level to the full-gate voltage V_{GSP} . During rise time, drain current rises from zero to full-on current I_D . Thus, the total turn-on time $t_{on} = t_{d(on)} + t_r$. The turn-on time can be reduced by using low-impedance gate-drive source.

As the MOSFET is the majority carrier device, turn-off process is initiated soon after removal of gate voltage at time t_1 . The **turn-off delay time** $t_{d(off)}$ is the time required for the input capacitance to discharge from the overdrive gate voltage V_1 to the pinch-off-region. V_{GS} must decrease significantly before V_{DS} begins to rise. The **fall time**, t_f is the time that is required for the input capacitance to discharge from the pinch-off region to threshold voltage V_{GST} . If $V_{GS} \leq V_{GST}$, the transistor turns off. During fall time, drain current reduces from I_D to zero.

INTRODUCTION TO SNUBBER AND DRIVER CIRCUITS

A snubber circuit limits or stops (snubs) switching voltage amplitude and its rate of rise, therefore reducing power dissipation. In its simplest form, a snubber circuit basically consists of a resistor and capacitor connected across the thyristor.

MOSFET DRIVER CIRCUIT

A driver circuit need to turn on the semiconducting devices. A MOSFET usually needs a gate driver to do the on/off operation at the desired frequency. For high frequencies, MOSFETs require a gate drive circuit to translate the on/off signals from an analog or digital controller into the power signals necessary to control the MOSFET. Since the MOSFET is a voltage-driven device, no DC current flows into the gate. In order to turn on a MOSFET, a voltage higher than the rated gate threshold voltage V_{th} must be applied to the gate. While in a steady on or off state, the MOSFET gate drive basically consumes no power. The gate-source capacitance of a MOSFET seen by the driver output varies with its internal state. MOSFETs are often used as switching devices at frequencies ranging from several kHz to more than several hundreds of kHz. The low power consumption needed for gate drive is an advantage of a MOSFET as a switching device. MOSFETs designed for low-voltage drive are also available.

The basic requirements for a MOSFET drive circuit include an ability to apply a voltage sufficiently higher than V_{th} to the gate and a drive capability to sufficiently charge the input capacitance. This section describes an example of a drive circuit for an N-channel MOSFET.

The below figure shows a basic MOSFET drive circuit. In practice, the capacitance of a MOSFET to be driven and its usage conditions must be considered in designing a drive circuit.

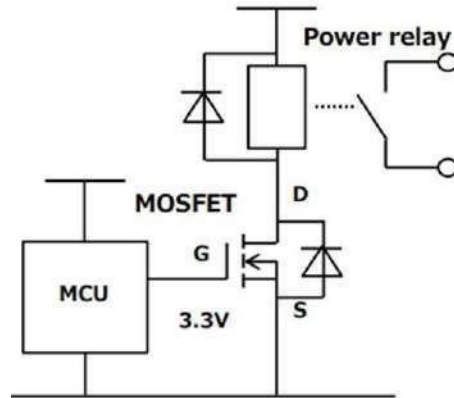

There is a growing need for MOSFETs for switching applications (load switches) to provide a conducting path in a circuit only when it is operated, and thereby reduce the power consumption of electronic devices. At present, MOSFETs are directly driven by a logic circuit or a microcontroller in many applications. Figure 2.2 shows an example of a circuit for turning on and off a power relay. Since turn-on and turn-off times may be as slow as a few seconds for load switches, the MOSFET gate can be driven with a small current. There are other ways of triggering MOSFET are using a high-voltage device and a bootstrap circuit, Pulse transformer drive (insulated switching) ,using a photo coupler and a floating power supply.

BUCK CONVERTER

DEFINITION:

Buck Converter is a type of chopper circuit that is designed to perform step-down conversion of the applied dc input signal. In the case of buck converters, the fixed dc input signal is changed into another dc signal at the output which is of lower value. This means it is

designed to produce a dc signal as its output that possesses a lower magnitude than the applied input.

INTRODUCTION

Choppers are the circuits that are designed to perform the conversion of a fixed dc signal into an adjustable dc signal. It is mainly designed to increase or decrease the voltage level of the signal applied at its terminals.

There are various power semiconductor devices such as power BJT, power MOSFET, IGBT, GTO, etc. that acts as a switch in the chopper circuits. The use of thyristor is generally prohibited in chopper circuits and the reason behind the same is that in order to commutate a thyristor, an external commutation circuit is required. While power MOSFET or IGBT can be turned off by maintaining zero potential between the gate to source terminal for MOSFET or gate to collector terminal for IGBT.

We have mentioned in the beginning itself that choppers are designed to produce such a dc signal at the output which is more or less than that of the applied input signal. A buck converter is a type of chopper which is designed to generate a lower value at its output from the fixed dc input signal.

The figure given below shows the circuit representation of Buck Converter:

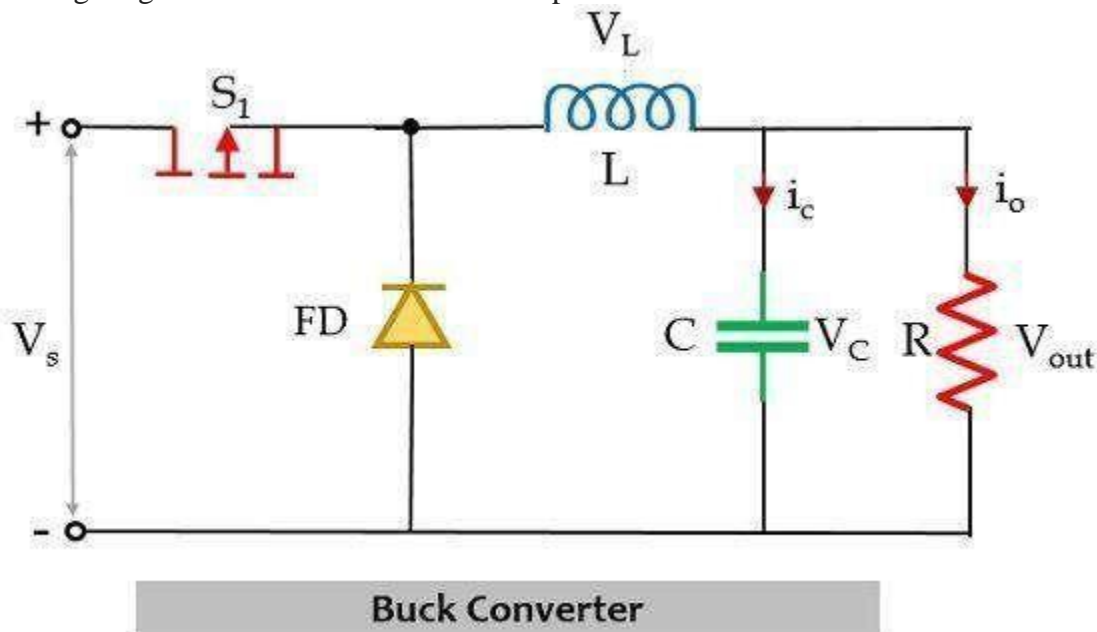

OPERATING PRINCIPLE OF BUCK CONVERTER

In the above figure, it is clearly shown that along with the power electronics solid-state device which acts as a switch for the circuit, there is another switch in the circuit which is a freewheeling diode. The combination of these two switches forms a connection with a low-pass LC filter in order to reduce current or voltage ripples. This helps in generating regulated dc output. A pure resistor is connected across this whole arrangement that acts as a load of the circuit.

The whole operation of the circuit takes place in two modes. The first mode is the one when the power MOSFET i.e., switch S_1 is closed.

this mode of operation, switch S_1 is in closed condition thus allows the flow of current to take place through it.

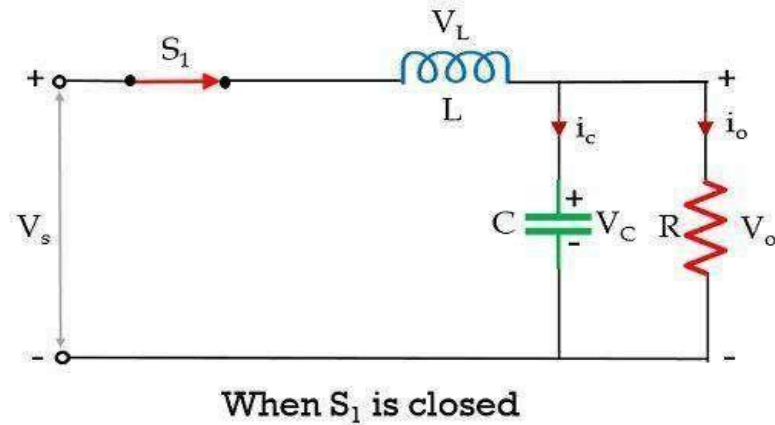

Initially when a fixed dc voltage is applied across the input terminal of the circuit then in the closed condition of switch S_1 current flows in the circuit in the manner shown above. Due to this flowing current, the inductor in the path stores energy in the form of a magnetic field. Also, there is a capacitor in the circuit and current flows through it also, therefore, it will store the charge and the voltage across it will appear across the load.

However, due to Lenz's law, the energy stored within the inductor will oppose the cause which has produced it and so an induced current will get generated and the polarity across the inductor will get reversed.

Here the total time period is a combination of T_{on} and T_{off} time.

$$T = T_{on} + T_{off}$$

The duty cycle is written as:

$$D = \frac{T_{on}}{T}$$

On applying KVL, in the above-given circuit,

$$V_s = V_L + V_{out}$$

$$V_L = V_s - V_{out}$$

Also,

$$V_L = L \frac{di_L}{dt} = V_s - V_{out}$$

$$\frac{di_L}{dt} = \frac{V_s - V_{out}}{L}$$

When S1 is in closed condition then $T_{on} = DT$ thus $\Delta t = DT$. Therefore, we can write,

$$\frac{\Delta i_L}{\Delta t} = \frac{V_s - V_{out}}{L}$$

$$\frac{\Delta i_L}{DT} = \frac{V_s - V_{out}}{L}$$

$$\Delta i_L = \left(\frac{V_s - V_{out}}{L} \right) DT$$

Hence,

The above equation represents the change in current through the circuit when switch S1 is closed.

Now, the second mode of operation takes place when switch S_2 is closed and S_1 gets open. However, you must be thinking about how automatically, the switch S_2 will be closed. So, as we have discussed that the inductor in the circuit will store the energy so, once S_1 will get open the inductor in the circuit will start acting as the source.

In this mode, the inductor releases the energy which is stored in the previous mode of operation. As we have discussed that the polarity of the inductor will get reversed therefore this causes the freewheeling diode to come in a forward-biased state which was earlier present in a reverse-biased state due to the applied dc input.

Due to this, the flow of current takes place in a way as shown below:

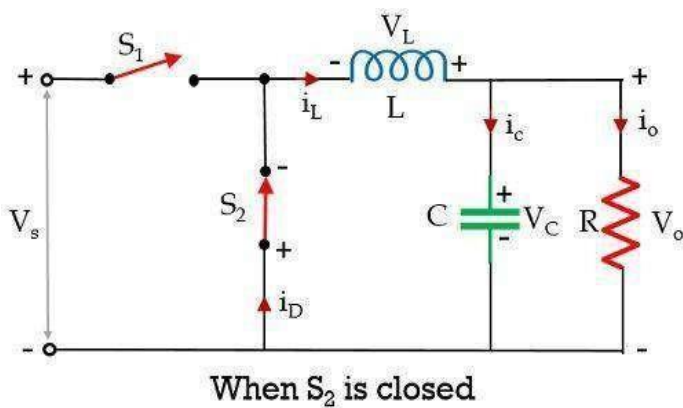

This flow of current will take place till the time the stored energy within the inductor gets completely collapsed. As once the inductor gets completely discharged, the diode comes

in reverse biased condition leading to cause opening of switch S_2 , and instantly switch S_1 will get closed and the cycle continues.

Now, let us apply KVL, in the above circuit,

$$0 = V_L + V_{out}$$

$$V_L = L \frac{di_L}{dt} = -V_{out}$$

Since, we know,

$$T = T_{on} + T_{off}$$

$$T = DT + T_{off}$$

$$T_{off} = T - DT$$

$$T_{off} = (1 - D)T$$

$$V_L = L \frac{\Delta i_L}{\Delta t} = -V_{out}$$

$$T_{off} = \Delta t = (1 - D)T$$

$$L \frac{\Delta i_L}{(1 - D)T} = -V_{out}$$

So,
$$\Delta i_L = -\frac{V_{out}}{L}(1 - D)T$$

This equation represents the rate of change in current through the inductor when the switch S_1 is open.

As we know that the net change of current through the inductor in one complete cycle is zero. Thus,

$$\Delta i_{L(S1-closed)} + \Delta i_{L(S1-open)} = 0$$

$$\frac{V_s - V_{out}}{L} DT + \left\{ -\frac{V_{out}}{L}(1 - D)T \right\} = 0$$

On simplifying,

$$\frac{V_s DT}{L} - \frac{V_{out} DT}{L} - \frac{V_{out} T}{L} + \frac{V_{out} DT}{L} = 0$$

$$\left(\frac{V_s DT}{L} \right) = \frac{V_{out} T}{L}$$

$$V_{out} = DV_s$$

The figure given below represents the waveform representation of Buck Converter:

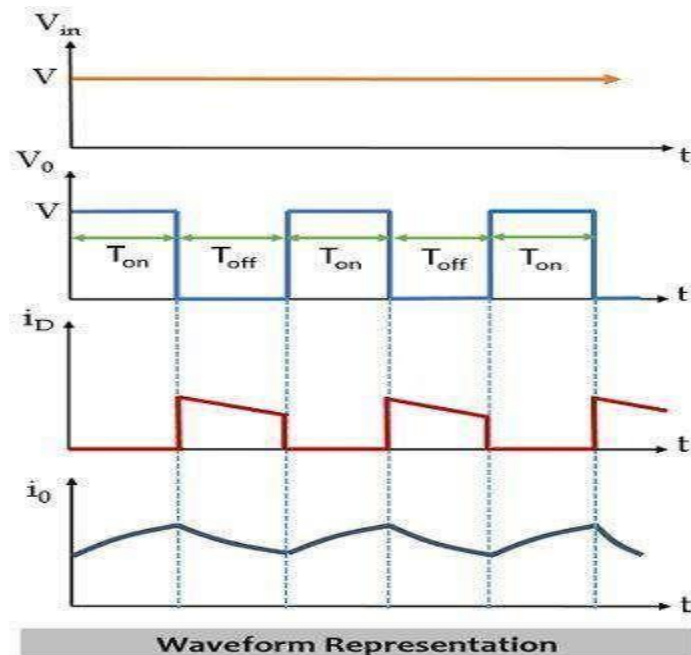

BOOST CONVERTER

DEFINITION:

Boost Converters sometimes, also known as step-up choppers are the type of chopper circuits that provides such an output voltage that is more than the supplied input voltage. In the case of boost converters, the dc to dc conversion takes place in a way that the circuit provides a high magnitude of output voltage than the magnitude of the supply input. It is given the name 'boost' because the obtained output voltage is higher than the input voltage.

INTRODUCTION

We have already mentioned in the beginning that boost converters are types of chopper circuits. In chopper circuits, we have discussed that it performs dc to dc conversion, i.e., a fixed dc voltage is changed into an adjustable dc voltage. Previously, we have seen another type of chopper circuit i.e., buck converter. Buck converters generate an output voltage that is lower than the supplied input. So, we can say, boost

converters are the ones that perform a reverse operation of the buck converter. Due to the type of operation performed by boost converters, these are referred to as **step-up choppers**.

It is to be noted here that since the product of voltage and current results in power then with the increase in the output voltage, the output current through the circuit will automatically decrease.

In chopper circuits, power MOSFET, BJT, IGBT, etc. are used as switches while the thyristors are not used for such purposes and the reason for the same is that an external commutation circuit is needed in order to commutate the device.

OPERATING PRINCIPLE OF BOOST CONVERTER

The figure given below is the circuit representation of the boost converter:

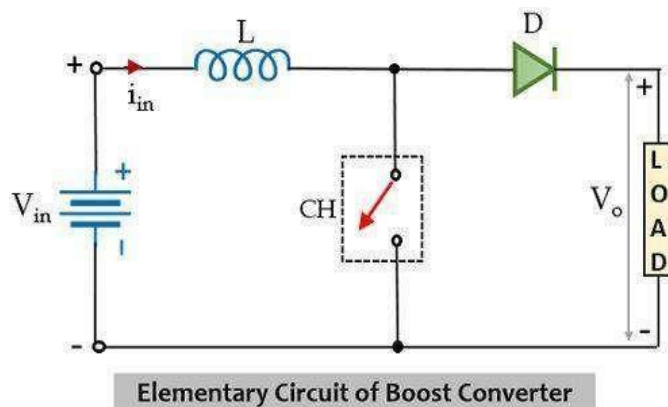

The circuit here is an elementary form of step-up chopper which necessarily requires a large inductor L in series connection with the voltage source. The whole circuit arrangement operates in a way that it helps in maintaining a regulated dc signal at the output.

Let us understand how the given circuit operates in order to provide an increased dc signal at the load.

Initially, when the chopper CH is in on state, then in the presence of supply dc input current begins to flow through the closed path of the circuit i.e., passing through the inductor as shown in the figure below.

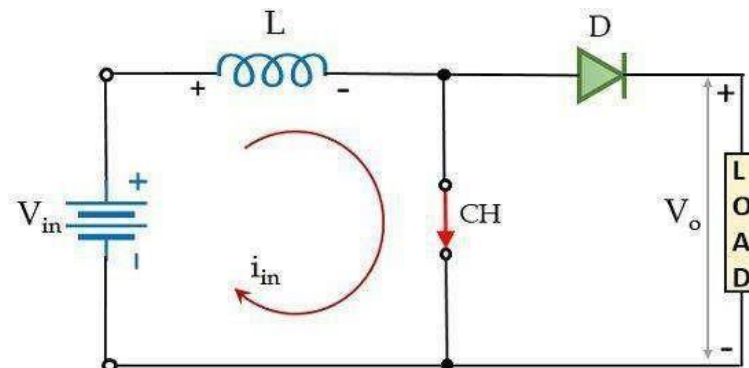

Here, the polarity of the inductor will be according to the direction of the flow of current. In this particular case, the diode in the configuration is in reverse biased condition and so current will not be allowed to flow through that particular part of the circuit during on state of the chopper. Resultantly, the voltage across the chopper will appear across the load.

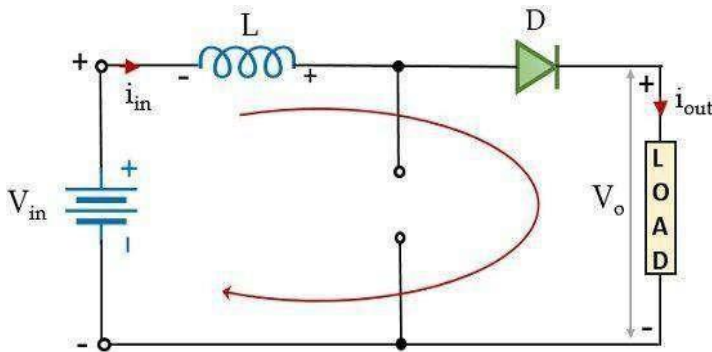

Furthermore, at the instant when CH is in the off state, then the part of the circuit through which the current was flowing earlier will not be active in this case. However, as the inductor stores, the energy in the form of a magnetic field and so the current through it will not die out instantly.

Also, we know according to Lenz's law a reverse current will be induced that will oppose the cause which has produced it. And so, due to the induced current, the polarity of the inductor will get reversed. This reverse polarity of the inductor forward biases the diode present in the circuit. This provides the path for the current through the diode that flows through the load during the off state of the chopper i.e., T_{off} . However, we must note here that the current through the inductor is of decreasing nature and will die out after a point in time.

Thus, the total voltage across the load will be given as:

$$V_{out} = V_{in} + V_L$$

This means that the output voltage exceeds the applied input voltage. Thus, performs step-up conversion as the energy stored within the inductor during the T_{on} period is released during the T_{off} period.

During the T_{on} period, the voltage across the inductor will be given as:

$$V_L = L \frac{di}{dt}$$

Let us have a look at the waveform representation of the step-up chopper shown below:

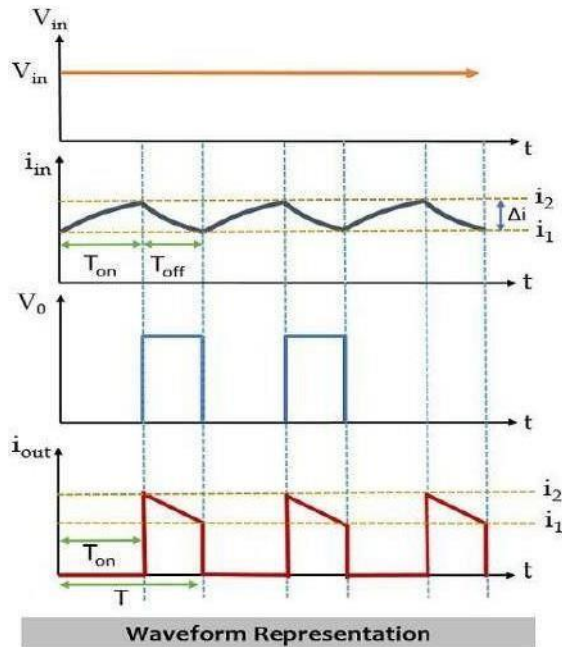

During the T_{on} period, the current through the inductor will change from i_1 to i_2 this is clearly shown above. While during the T_{off} period, the inductor current will change from i_2 to i_1 . Now, talking about voltage, so during the turn-on period, the voltage across the inductor will be equal to the supply input voltage. But when CH gets off then on applying KVL in the figure shown above, we will get,

$$V_L - V_0 + V_{in} = 0$$

This means,

$$V_L = V_0 - V_{in}$$

Considering that output current is varying linearly, the energy input provided by the source to the inductor, when CH is on, is given as:

$$W_{on} = (\text{voltage across the inductor})(\text{average current through the inductor})T_{on}$$

$$W_{on} = V_{in} \left(\frac{i_1 + i_2}{2} \right) T_{on}$$

Further, the energy that the inductor releases to the load when CH is off is given as:

$$W_{off} = (\text{voltage across the inductor})(\text{average current through the inductor})T_{off}$$

$$W_{off} = V_{out} - V_{in} \left(\frac{i_1 + i_2}{2} \right) T_{off}$$

For a lossless system, comparing the two energies, we will have,

$$V_{in} \left(\frac{i_1 + i_2}{2} \right) T_{on} = V_{out} - V_{in} \left(\frac{i_1 + i_2}{2} \right) T_{off}$$

On simplifying,

$$V_{in} T_{on} = V_{out} T_{off} - V_{in} T_{off}$$

$$V_{out} T_{off} = V_{in} T_{on} + V_{in} T_{off}$$

$$V_{out} T_{off} = V_{in} (T_{on} + T_{off})$$

Since we know, $T = T_{on} + T_{off}$, therefore,

$$V_{out} T_{off} = V_{in} T$$

$$V_{out} = V_{in} \frac{T}{T_{off}}$$

$$V_{out} = V_{in} \frac{T}{T - T_{on}}$$

$$V_{out} = V_{in} \frac{1}{\left(\frac{T}{T} - \frac{T_{on}}{T} \right)}$$

Since, we know, duty cycle i.e., $\alpha = T_{on}/T$

$$V_{out} = V_{in} \frac{1}{(1 - \alpha)}$$

Thus, we can conclude here that the average load voltage can be stepped up with the change in the duty cycle.

APPLICATIONS

Due to the operating principle of step-up choppers, these find applications in the regenerative braking of dc motors. Along with this, these are used in various consumer electronics, battery power systems, power amplifier circuits, power factor correction circuits, automotive equipment, etc.

BUCK BOOST CONVERTER

The buck boost converter is a DC to DC converter. The output voltage of the DC to DC converter is less than or greater than the input voltage. The output voltage of the

magnitude depends on the duty cycle. These converters are also known as the step up and step-down transformers and these names are coming from the analogous step up and step-down transformer. The input voltages are step-up/down to some level of more than or less than the input voltage. By using the low conversion energy, the input power is equal to the output power. The following expression shows the low of a conversion.

For the step-up mode, the input voltage is less than the output voltage ($V_{in} < V_{out}$). It shows that the output current is less than the input current. Hence the buck booster is a step up mode.

In the step down mode the input voltage is greater than the output voltage ($V_{in} > V_{out}$). It follows that the output current is greater the input current. Hence the buck boost converter is a step down mode.

$$V_{in} > V_{out} \text{ and } I_{in} < I_{out}$$

It is a type of DC to DC converter and it has a magnitude of output voltage. It may be more or less than equal to the input voltage magnitude. The buck boost converter is equal to the fly back circuit and single inductor is used in the place of the transformer. There are two types of converters in the buck boost converter that are buck converter and the other one is boost converter. These converters can produce the range of output voltage than the input voltage. The following diagram shows the basic buck boost converter.

On-State

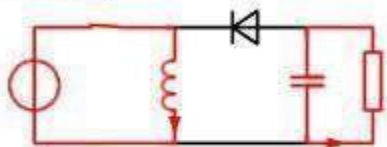

Off-State

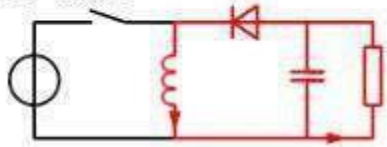

Buck Boost Converter

WORKING PRINCIPLE OF BUCK-BOOST CONVERTER

The working operation of the DC to DC converter is the inductor in the input resistance has the unexpected variation in the input current. If the switch is ON then the inductor feeds the energy from the input and it stores the energy of magnetic energy. If the switch is closed it discharges the energy. The output circuit of the capacitor is assumed as high sufficient than the time constant of an RC circuit is high on the output stage. The huge time constant is compared with the switching period and make sure that the steady state is a constant output voltage $V_o(t) = V_o(\text{constant})$ and present at the load terminal.

There are two different types of working principles in the buck boost converter.

- Buck converter.
- Boost converter.

BUCK CONVERTER WORKING

The following diagram shows the working operation of the buck converter. In the buck converter first transistor is turned ON and second transistor is switched OFF due to high square wave frequency. If the gate terminal of the first transistor is more than the current pass through the magnetic field, charging C, and it supplies the load. The D1 is the Schottky diode and it is turned OFF due to the positive voltage to the cathode.

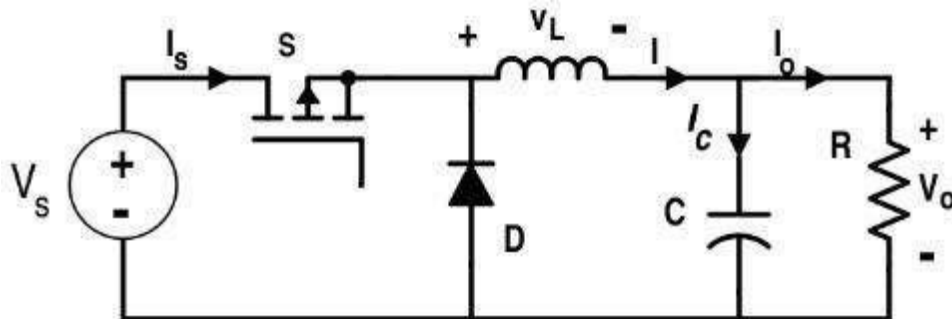

Buck Converter

WORKING

The inductor L is the initial source of current. If the first transistor is OFF by using the control unit then the current flow in the buck operation. The magnetic field of the inductor is collapsed and the back e.m.f is generated collapsing field turn around the polarity of the voltage across the inductor. The current flows in the diode D2, the load and the D1 diode will be turned ON.

The discharge of the inductor L decreases with the help of the current. During the first transistor is in one state the charge of the accumulator in the capacitor. The current flows through the load and during the off period keeping V_{out} reasonably. Hence it keeps the minimum ripple amplitude and V_{out} closes to the value of V_s

BOOST CONVERTER WORKING

In this converter the first transistor is switched ON continually and for the second transistor the square wave of high frequency is applied to the gate terminal. The second transistor is in conducting when the on state and the input current flow from the inductor L through the second transistor. The negative terminal charging up the magnetic field around the inductor. The D2 diode cannot conduct because the anode is on the potential ground by highly conducting the second transistor.

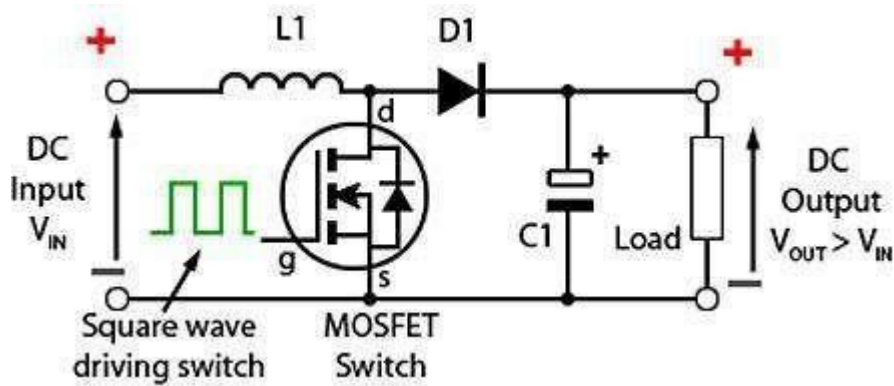

Boost Converter

WORKING

By charging the capacitor C the load is applied to the entire circuit in the ON State and it can construct earlier oscillator cycles. During the ON period the capacitor C can discharge regularly and the amount of high ripple frequency on the output voltage. The approximate potential difference is given by the equation below.

$$V_S + V_L$$

During the OFF period of second transistor the inductor L is charged and the capacitor C is discharged. The inductor L can produce the back e.m.f and the values are depending up on the rate of change of current of the second transistor switch. The amount of inductance the coil can occupy. Hence the back e.m.f can produce any different voltage through a wide range and determined by the design of the circuit. Hence the polarity of voltage across the inductor L has reversed now.

The input voltage gives the output voltage and atleast equal to or higher than the input voltage. The diode D2 is in forward biased and the current applied to the load current and it recharges the capacitors to $V_S + V_L$ and it is ready for the second transistor.

MODES OF BUCK BOOST CONVERTERS

There are two different types of modes in the buck boost converter. The following are the two different types of buck boost converters.

- Continuous conduction mode.
- Discontinuous conduction mode.

CONTINUOUS CONDUCTION MODE

In the continuous conduction mode the current from end to end of inductor never goes to zero. Hence the inductor partially discharges earlier than the switching cycle.

DISCONTINUOUS CONDUCTION MODE

In this mode the current through the inductor goes to zero. Hence the inductor will totally discharge at the end of switching cycles.

APPLICATIONS OF BUCK BOOST CONVERTER

- It is used in the self regulating power supplies.
- It has consumer electronics.
- It is used in the Battery power systems.
- Adaptive control applications.
- Power amplifier applications.

ADVANTAGES OF BUCK BOOST CONVERTER

- It gives higher output voltage.
- Low operating duct cycle.
- Low voltage on MOSFETs

Thus, this is all about the Buck Boost Converter Circuit Working and applications. The information given in the article is the basic concept of buck boost converters.

ISOLATED TOPOLOGY

SMPS FLYBACK TRANSFORMER DESIGN

SMPS flyback transformer design is more popular than normal power supply designs because of its low cost, efficiency, and simple design. It isolates the primary and secondary winding of the transformer for given multiple inputs and provide multiple output voltages, which may be positive or negative.

The basic SMPS flyback transformer design when the switch is turned ON and OFF is shown below. It is also used as an isolated power converter. The flyback transformer used in the design contains primary and secondary winding, separated electrically to avoid transient coupling, ground loops, and provides flexibility.

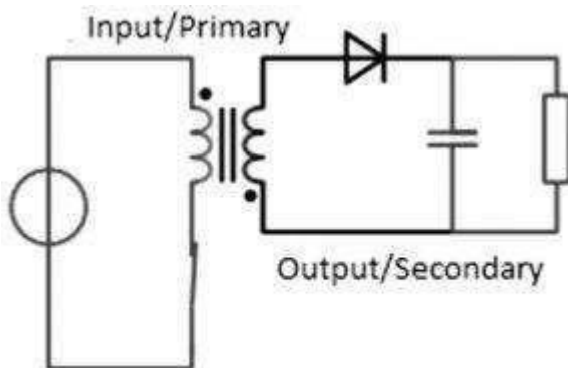

The use of SMPS flyback transformer design has an advantage over conventional transformer design. Here the current doesn't flow through the primary and secondary winding at the same time because the phase of the winding gets reversed as shown in the above figure.

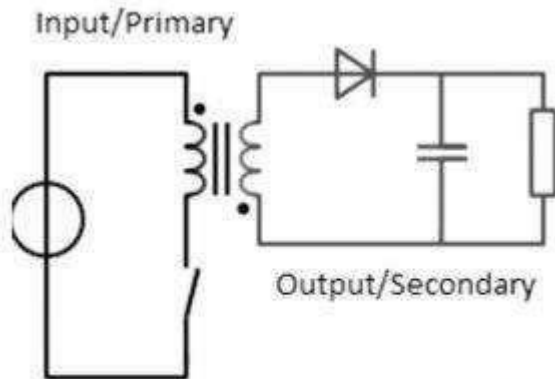

©Elprocus.com Transformer Switch is OFF

It stores the energy in the form of the magnetic field in the primary winding for a certain amount of time and transfers to the primary winding. The maximum output load voltage, operating ranges, input and output voltage ranges, power delivery capability, and the characteristics of flyback cycles are the important parameters in the SMPS flyback transformer design.

APPLICATIONS

The **flyback converter applications** are,

- Used in television sets, and pcs with low power of up to 250W
- Used in Stand by power supplies in electronic pcs (low power switch mode)
- Used in mobile phones and mobile chargers
- Used in high voltage supplies like television, CRTs, Lasers, flashlights, and copy devices, etc.
- Used in multiple input-output power supplies
- Used in isolated gate drive circuits.

The **forward converter** is a DC/DC converter that uses a transformer to increase or decrease the output voltage (depending on the transformer ratio) and provide galvanic isolation for the load. With multiple output windings, it is possible to provide both higher and lower voltage outputs simultaneously.

While it looks superficially like a flyback converter, it operates in a fundamentally different way, and is generally more energy efficient. A flyback converter stores energy in the magnetic field in the transformer air gap during the time the converter switching element (transistor) is conducting. When the switch turns off, the stored magnetic field collapses and the energy is transferred to the output of the flyback converter as electric current. The flyback

converter can be viewed as two inductors sharing a common core with opposite polarity windings.

In contrast, the forward converter (which is based on a transformer with same-polarity windings, higher magnetizing inductance, and no air gap) does not store energy during the conduction time of the switching element — transformers cannot store a significant amount of energy, unlike inductors.^[1] Instead, energy is passed directly to the output of the forward converter by transformer action during the switch conduction phase.

While the output voltage of a flyback converter is theoretically infinite, the maximum output voltage of the forward converter is constrained by the transformer turns ratio where is the pulse width modulator duty cycle.

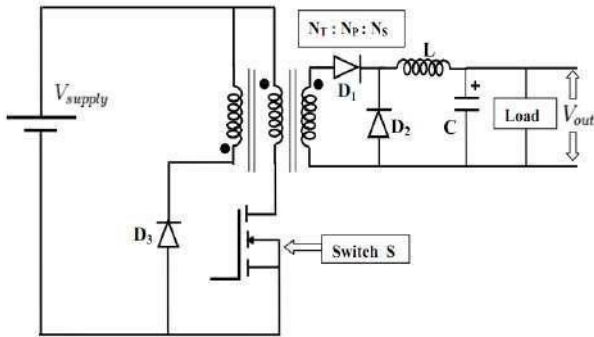

RESONANT CONVERTERS

A resonant converter is a type of power electronic circuit used for efficient DC-to-DC voltage conversion. It operates by utilizing the resonant behavior of certain components, such as inductors and capacitors, to achieve high-efficiency power conversion. Resonant converters are commonly used in various applications, including power supplies for electronic devices, renewable energy systems, and electric vehicles.

There are several types of resonant converters, with the most common ones being:

1. **ZERO-VOLTAGE SWITCHING (ZVS) RESONANT CONVERTER:**

In a ZVS resonant converter, the switching of the power semiconductor devices (typically transistors or MOSFETs) occurs when the voltage across them is zero. This minimizes switching losses and enhances efficiency. ZVS converters are often used in high-power applications.

2. **ZERO-CURRENT SWITCHING (ZCS) RESONANT CONVERTER:**

Similar to ZVS converters, ZCS resonant converters focus on minimizing current stress during switching. They turn on the power switches when the current through them is zero, reducing switching losses and improving efficiency.

3. **SERIES RESONANT CONVERTER (SRC):**

The series resonant converter operates by connecting the inductor and capacitor in series with the load. It is known for its high efficiency and voltage

regulation capabilities. However, SRCs are more complex to design and control compared to other resonant converters.

4. **PARALLEL RESONANT CONVERTER (PRC):**

In a parallel resonant converter, the inductor and capacitor are connected in parallel with the load. PRCs are relatively simpler to design and control compared to SRCs but may have slightly lower efficiency.

Resonant converters offer several advantages over traditional pulse-width modulation (PWM) converters, including:

- **Higher efficiency:** Resonant converters reduce switching losses, leading to improved efficiency, especially at high switching frequencies.
- **Lower electromagnetic interference (EMI):** The soft-switching nature of resonant converters reduces the generation of EMI, making them suitable for sensitive electronic equipment.
- **Improved reliability:** Reduced stress on power semiconductors and passive components can lead to increased reliability.
- **Better thermal performance:** Lower switching losses result in less heat generation in power components.

However, designing and controlling resonant converters can be more complex than conventional converters, and they may have limitations in terms of operating range and voltage regulation. Engineers often choose the type of resonant converter based on specific application requirements, such as input voltage range, output voltage regulation, and power levels.

SWITCHING LOSS CALCULATION AND THERMAL DESIGN

Switching loss calculation and thermal design are crucial aspects when working with MOSFETs (Metal-Oxide-Semiconductor Field-Effect Transistors) in electronic circuits, especially in high-power applications like power supplies and motor control. Let's delve into both topics:

1. **SWITCHING LOSS CALCULATION:**

Switching losses occur when the MOSFET transitions between its on and off states during operation. These losses can be divided into two main components:

- a. **TURN-ON LOSSES:** These losses occur during the time it takes for the MOSFET to transition from the off-state to the on-state. The key factors affecting turn-on losses are the gate voltage and gate resistance.
- b. **TURN-OFF LOSSES:** These losses happen when the MOSFET switches from the on-state to the off-state. Key factors affecting turn-off losses are the gate voltage, gate resistance, and the body diode.

To calculate switching losses, you can use the following simplified equations:

TURN-ON LOSSES (EON):

$$E_{on} = 0.5 * C_{oss} * V_{DS}^2 * f_{sw}$$

TURN-OFF LOSSES (EOFF):

$$E_{off} = 0.5 * C_{oss} * V_{DS}^2 * f_{sw}$$

Where:

- C_{oss} is the output capacitance of the MOSFET.
- V_{DS} is the drain-source voltage.
- f_{sw} is the switching frequency.

The total switching loss (E_{sw}) is $E_{on} + E_{off}$.

2. **THERMAL DESIGN:**

Proper thermal design is essential to ensure that the MOSFET stays within its safe operating temperature range. Here are some steps for thermal design:

a. **HEAT SINK:** Use an appropriate heat sink with the MOSFET to dissipate heat. The size and material of the heat sink should be selected based on the power dissipation and thermal resistance requirements.

b. **THERMAL RESISTANCE ($R_{\theta JA}$ AND $R_{\theta JC}$):** MOSFET datasheets provide thermal resistance values, such as junction-to-ambient ($R_{\theta ja}$) and junction-to-case ($R_{\theta jc}$). These values help you understand how efficiently the MOSFET dissipates heat. Lower thermal resistance is better.

c. **TEMPERATURE MONITORING:** Implement temperature monitoring using sensors to ensure that the MOSFET's junction temperature does not exceed its maximum rated value. This can be done with a thermal cutoff circuit or by using a microcontroller to monitor temperature and control the MOSFET's operation.

d. **PROPER PCB LAYOUT:** Ensure that the MOSFET is mounted on a well-designed PCB with proper copper traces for heat dissipation.

e. **Cooling Fans:** In some cases, cooling fans or other active cooling methods may be necessary to maintain the MOSFET's temperature within limits.

f. **DERATING:** Consider derating the MOSFET's current and voltage ratings if operating conditions are not ideal. This means using a MOSFET with higher specifications than the minimum requirements to reduce stress and heat generation.

g. **THERMAL INTERFACE MATERIAL:** Use a high-quality thermal interface material (TIM) between the MOSFET and the heat sink to improve heat transfer.

By properly calculating switching losses and designing for efficient heat dissipation, you can ensure the reliable and safe operation of MOSFETs in your electronic circuits, particularly in high-power applications.

UNIT-II

INVERTERS

STATIC BEHAVIOUR OF IGBT

VI characteristics of IGBT is the graphical relationship between collector current and collector-emitter voltage (V_{CE}) for different values of gate-emitter voltages. It is basically a plot of collector current (I_C) versus collector-emitter voltage for various values of gate-emitter voltage (V_{GE}).

VI characteristics of IGBT is also known as Static or Output Characteristics. Let us now discuss the required circuit diagram and VI characteristics.

The circuit diagram for obtaining VI characteristics of IGBT is shown below. This circuit comprises of voltage source V_{CC} to make the IGBT (*Insulated Gate Bipolar Transistor*) collector-emitter forward biased, resistor R_s in series with the gate circuit and resistance R_{GE} connected in shunt with gate-emitter.

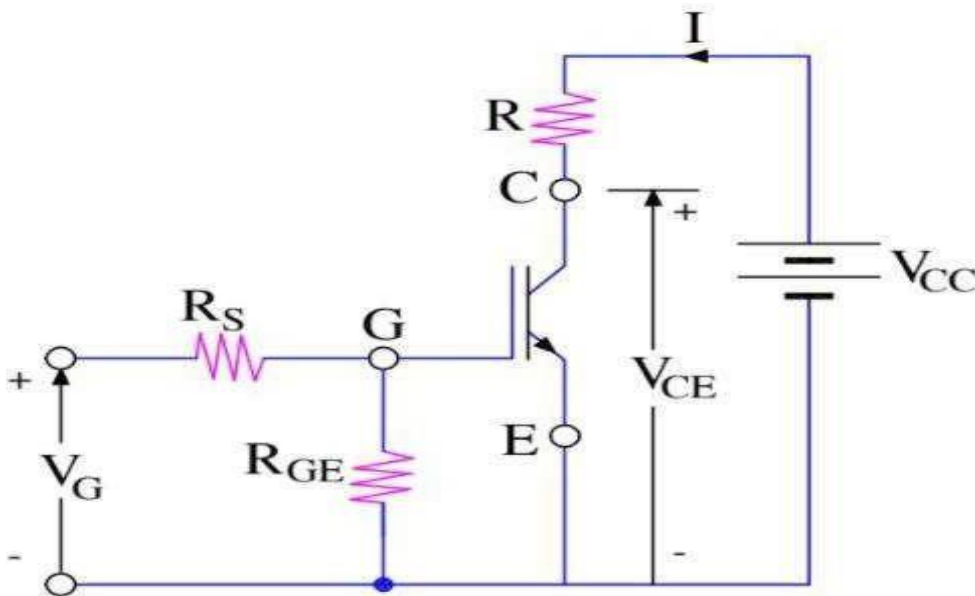

The gate-emitter voltage (V_{GE}) is varied and the collector-emitter voltage (V_{CE}) and collector current (I_C) is measured. Then a plot between I_C & V_{CE} is drawn. This plot is the required static characteristics of IGBT.

The VI characteristics of IGBT is shown below:

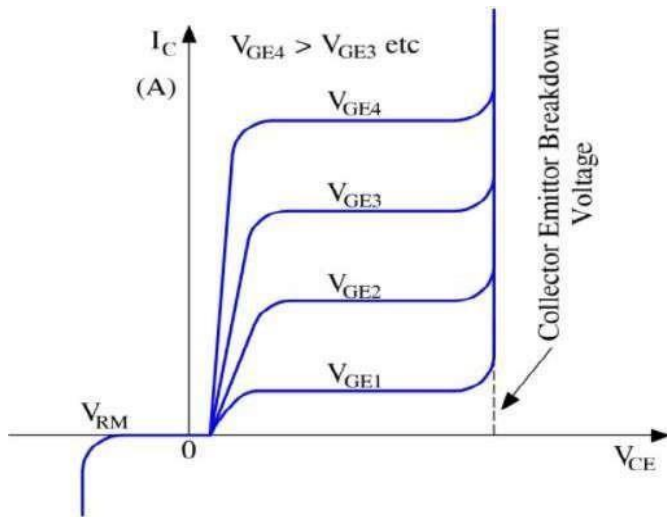

Following points may be noted from the above VI characteristics of IGBT:

- When the device is forward biased, the shape of output characteristics is similar to that of BJT. However, the controlling parameter in case of IGBT is V_{GE} as it is a voltage-controlled device.
- When the device is reversed biased, there is a voltage beyond which breakdown occurs. This reverse voltage is shown to be V_{RM} .
- There is a maximum voltage in forward conduction mode beyond which collector-emitter breakdown occurs and gate loses control of collector current.

There is one more static characteristic of IGBT which is called the transfer characteristics. Let us now discuss this in brief.

TRANSFER CHARACTERISTICS OF IGBT:

The transfer characteristics of IGBT is basically a plot of collector current I_C versus gate-emitter voltage (V_{GE}). The transfer characteristics is shown below.

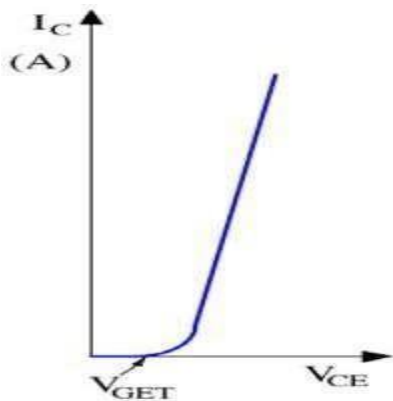

It may be noted from the above curve that when gate-emitter voltage is less than a minimum voltage (V_{GET}), no current flows through the IGBT. This means, a minimum amount of forward voltage is required to make IGBT turn ON.

DYNAMIC BEHAVIOR OF IGBT:

The turn-on time is defined as the time between the instant of forward blocking to forward conduction mode. Here, forward conduction means the device conducts in forward direction. Turn-on time (t_{on}) is basically composed of two different times: Delay time (t_{dn}) and Rise time (t_r). Therefore, we can say that $t_{on} = t_{dn} + t_r$.

The delay time is defined as the time for the collector-emitter voltage (V_{CE}) to fall from V_{CE} to $0.9V_{CE}$. This simply means that, the collector-emitter voltage drops to 90% in delay time and hence the collector current rises from initial leakage current to $0.1I_C$ (10%). Thus, delay time may also be defined as the time period during which collector current rises from zero (in fact a small leakage current) to 10% of the final value of collector current I_C . The rise time t_r is the time during which collector-emitter voltage falls from $0.9V_{CE}$ to $0.1V_{CE}$. This means, during rise time collector-emitter voltage falls to 10% from 90%. Therefore, the collector current builds up to final value of collector current I_C from 10%. After time t_{on} , the collector current becomes I_C and the collector-emitter voltage drops to very small value called conduction drop (V_{CES}).

A typical Switching Characteristics of an IGBT is shown below. You may correlate the delay time, rise time and turn-on time.

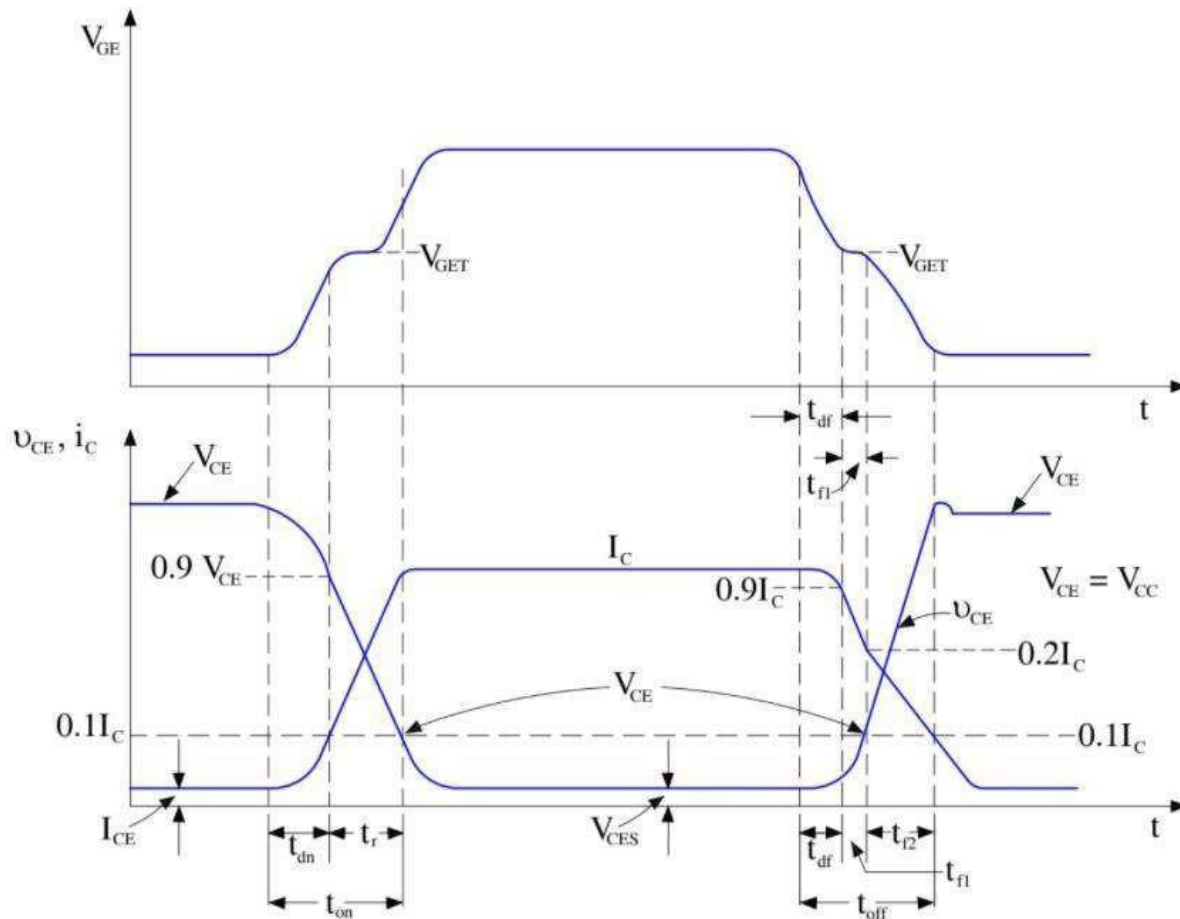

Let us now focus on turn-off time. Unlike turn-on time, turn-off time comprises of three intervals:

- Delay Time, t_{df}
- Initial Fall Time, t_{f1}
- Final Fall Time, t_{f2}

Thus, turn-off time is the sum of above three different time intervals i.e. $t_{off} = t_{df} + t_{f1} + t_{f2}$. Kindly refer the switching characteristics of IGBT for interpretation of above times. The delay time is the time during which gate voltage falls from V_{GE} to threshold voltage V_{GET} . As gate voltage falls to V_{GE} during t_{df} , the collector current falls from I_C to $0.9I_C$. At the end of delay time, collector-emitter voltage begins to rise.

The first fall time t_{f1} is defined as the time during which collector current falls from 90% to 20% of its final value I_C . In other words, it is the time during which collector-emitter voltage rises from V_{CES} to $0.1V_{CE}$.

The final fall time t_{f2} is the time during which collector current falls from 20% to 10% of I_C or the time during which collector-emitter voltage rises from $0.1V_{CE}$ to final value V_{CE} .

SINGLE PHASE HALF BRIDGE INVERTER:

Single Phase Half Bridge Inverter is a type of Single-Phase Bridge Inverter. It is a voltage source inverter. Voltage source inverter means that the input power of the inverter is a DC voltage Source. Basically, there are two different type of bridge inverters: Single Phase Half Bridge Inverter and Single-Phase Full Bridge Inverter.

As the input power source is DC, there is no meaning of single phase with respect to input power. However, it does have a meaning with reference to output. The output of single-phase bridge inverter is a single-phase output. Let us now discuss the basic operating or working principle of Single-Phase Half Bridge Inverter.

WORKING PRINCIPLE OF SINGLE-PHASE HALF BRIDGE INVERTER:

The working / operating principle of half bridge inverter is based on the fact that, for half of time period of output wave, one thyristor conducts whereas for another half of time period, another thyristor conducts. The output frequency of this type of inverter may be controlled by controlling the switch ON and switching OFF time of thyristors. Figure below shows the power circuit diagram of a single-phase half bridge inverter.

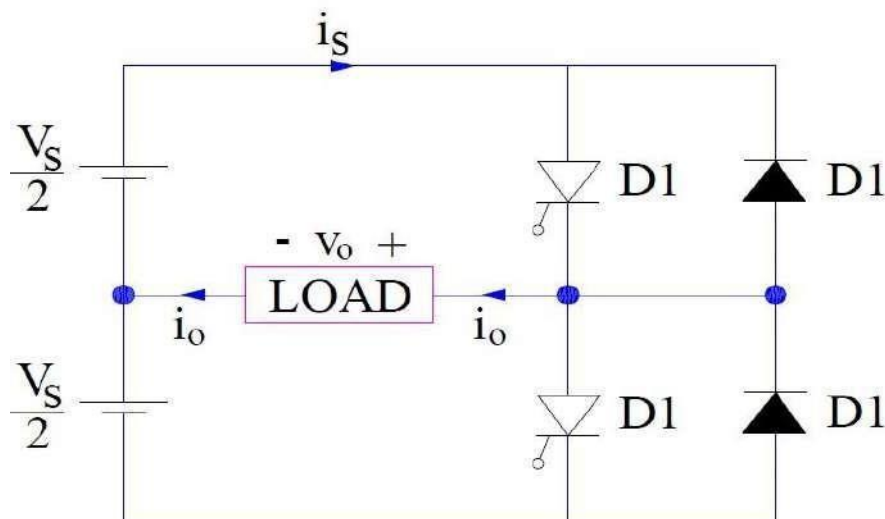

Single Phase Half Bridge Inverter comprises of two thyristors T1 & T2, two diodes D1 & D2 and three wire DC source. The circuit for turning ON and turning OFF the thyristor is not shown in the above circuit to maintain simplicity. While analyzing the circuit, it is assumed that each thyristor conducts for the duration its gate pulse is present and

is commutated as soon as this pulse is removed. The gating signal for thyristor T1 (i_{g1}) and thyristor T2 (i_{g2}) and output voltage waveform of this inverter is shown below.

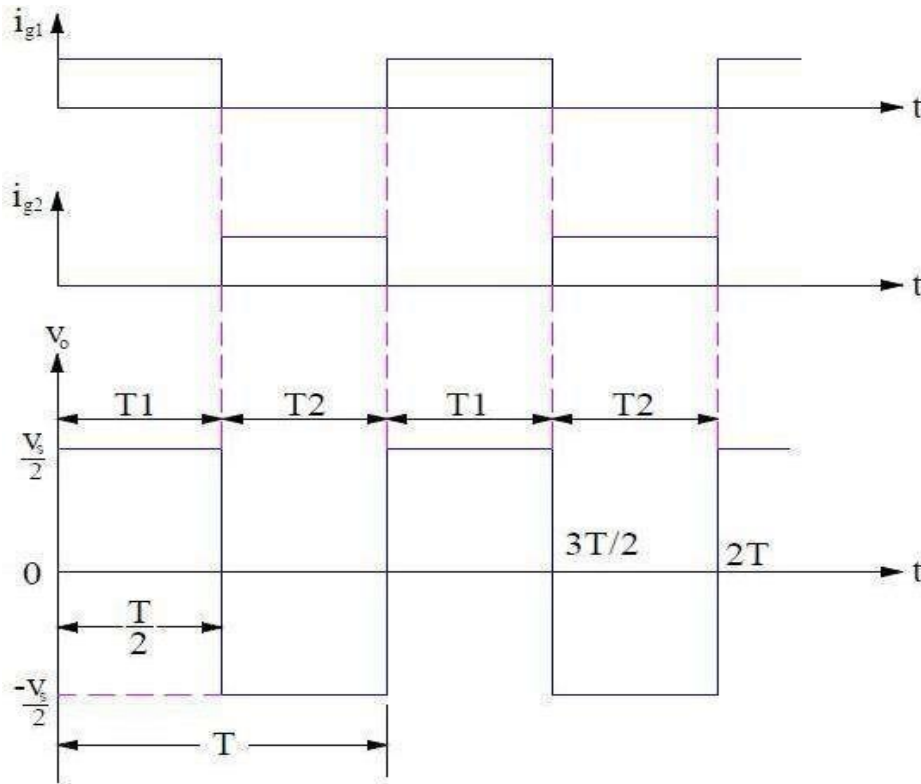

Carefully observe the gating signal for T1 & T2. It can be seen that i_{g1} is applied for a period of $0 < t \leq (T/2)$, this means thyristor T1 will conduct for this time period. During the time T1 conducts, load is directly connected to source ($V_s/2$) on the upper arm. Thus, the load voltage / output voltage will be equal to the input source voltage ($V_s/2$) for $0 < t \leq (T/2)$.

As soon as i_{g1} is removed at $t=T/2$, thyristor T1 gets turned OFF. It may be seen from the waveform of gating signal that at $t=T/2$, i_{g2} is applied and hence, thyristor T2 gets turned ON. Thus, load gets directly connected to the source ($V_s/2$) on the lower arm. Note that the polarity of voltage source on the upper & lower arm are opposite to each other. Therefore, during the time $(T/2) < t \leq T$, T2 is ON, the output voltage is $-(V_s/2)$ as shown in the output voltage waveform.

It may also be seen from the output voltage waveform that load voltage is an alternating square voltage waveform of amplitude ($V_s/2$) and frequency ($1/T$) Hz. Thus, output frequency can be controlled by controlling T .

PURPOSE OF DIODES IN HALF BRIDGE INVERTER:

If the load is purely resistive, there is no need to put diode D1 & D2 as the output voltage and current are always in phase. But unfortunately, for loads other than purely resistive, the load current (i_o) will not be in phase with the load voltage (v_o). For such case, the diode connected in anti-parallel with the thyristor will allow the current to flow when main thyristor is turned off. When these diode conducts, the energy is fed back to the DC source and hence, these diodes (D1 & D2) are called flyback diode.

DRAWBACKS:

The main drawback of single phase half bridge inverter is that it requires 3-wire DC supply source. However, this drawback can be overcome by the use of full bridge inverter.

SINGLE PHASE FULL BRIDGE INVERTER:

Single Phase Full Bridge Inverter is basically a voltage source inverter. Unlike Single Phase Half Bridge Inverter, this inverter does not require three wire DC input supply. Rather, two wire DC input power source suffices the requirement. The output frequency can be controlled by controlling the turn ON and turn OFF time of the thyristors.

CIRCUIT DIAGRAM OF SINGLE PHASE FULL BRIDGE INVERTER:

The power circuit of a single phase full bridge inverter comprises of four thyristors T1 to T4, four diodes D1 to D1 and a two wire DC input power source V_s . Each diode is connected in antiparallel to the thyristors viz. D1 is connected in anti-parallel to T1 and so on. The power circuit diagram of a single phase full bridge inverter is shown in the figure below.

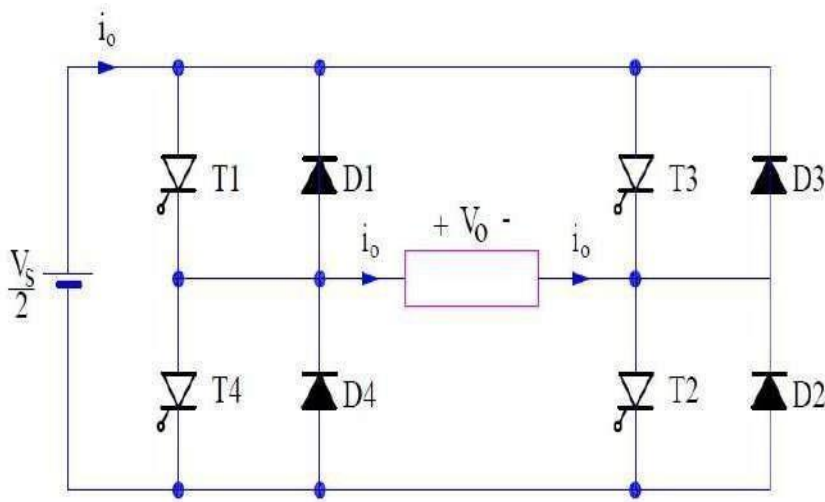

It may be noted that the circuitry for turning ON and turning OFF the thyristor is not shown in the above circuit diagram to maintain simplicity. Further, it is assumed that each of the thyristor only conducts for the period its gate signal is present and as soon as the gate signal is removed, the thyristors gets turned OFF.

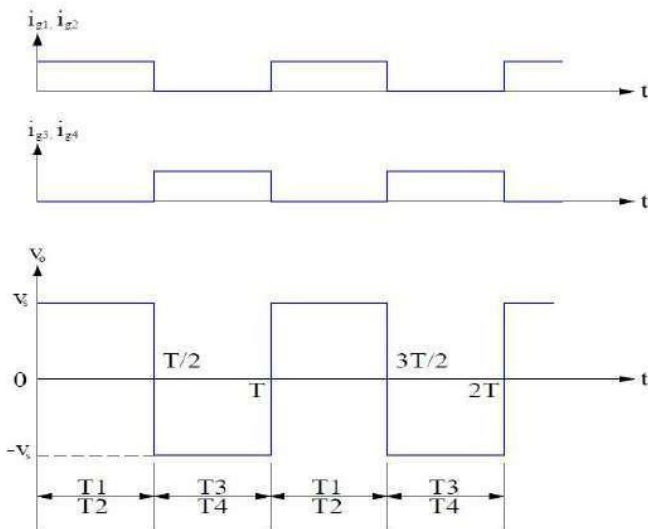

WORKING PRINCIPLE OF SINGLE PHASE FULL BRIDGE INVERTER:

The working principle of single phase full bridge inverter is based on the sequential triggering of thyristors placed diagonally opposite. This means, for half of time period, thyristors T3 & T4 will be triggered while for the remaining half of time period, T1 & T2 will be triggered. Only two thyristors are turned ON in half of the time period.

Carefully observe the waveform of the gating signal. You will notice that thyristors T1 & T2 are triggered simultaneously for a time $T/2$. Therefore, load is connected to source through T1 & T2 and hence, the load voltage is equal to the source voltage with positive polarity. This is the reason; the load voltage is shown positive & equal to V_s in the output voltage waveform.

As soon as the gate signal (i_{g1} & i_{g2}) are removed, T1 and T2 get turned OFF. However, at the same instant gate signal (i_{g3} & i_{g4}) are applied and hence, T3 & T4 are turned ON. When T3 & T4 are conducting, load gets connected to the source. The load voltage magnitude is again V_s but with reverse polarity. This is the reason, the output voltage is shown negative in the voltage waveform.

To summarize,

For the time $0 < t \leq (T/2)$, thyristors T1 & T2 conducts and load voltage $V_o = V_s$.

For the time $(T/2) < t \leq T$, thyristors T3 & T4 conducts and load voltage $V_o = -V_s$.

I think you have understood the working principle of single-phase half bridge inverter. But I am sure that you might be thinking the purpose of diodes D1 to D4. I will explain.

Purpose of Diodes D1 to D4:

If the load is purely resistive, there is no need to put diode D1 to D4 as the output voltage and current are always in phase. But unfortunately, for loads other than purely resistive, the load current (i_o) will not be in phase with the load voltage (v_o). For such case, the diode connected in anti-parallel with the thyristor will allow the current to flow when main thyristor is turned off. When these diode conducts, the energy is fed back to the DC source and hence, these diodes (D1 to D4) are called flyback diode.

SINGLE PULSE WIDTH MODULATION:

Single Pulse Width Modulation (SPWM) is a modulation technique used in electronics and electrical engineering to control the output voltage or power of an inverter or motor drive. It is primarily employed in applications like motor control, uninterruptible power supplies (UPS), and various power conversion systems. SPWM is an essential technique to generate a sinusoidal output voltage or current from a DC source.

Here's how SPWM works:

1. **Reference Signal:** You start with a reference signal, typically a sinusoidal waveform, which represents the desired output. This reference signal's frequency and amplitude are usually predetermined.
2. **Comparison:** The reference signal is compared with a high-frequency carrier signal, often a triangular waveform or a high-frequency square wave. The carrier signal has a fixed frequency and is typically generated by an oscillator.

3. **Pulse Generation:** The comparison between the reference signal and the carrier signal generates a series of pulses. The pulse width of these pulses is varied based on the instantaneous value of the reference signal concerning the carrier signal. The comparison results in a continuous stream of pulses that encode the desired waveform.
4. **Gate Control:** These pulses are then used to control the switching of semiconductor devices, like transistors or IGBTs, in the inverter circuit. The pulse width determines how long these devices are turned on during each cycle. This, in turn, regulates the output voltage or current.
5. **Output Generation:** The switching of these devices creates an approximation of the desired sinusoidal output waveform. By carefully controlling the pulse widths, you can create a waveform that closely matches the reference signal. The more frequently you switch the devices (higher carrier frequency), the closer the approximation to the desired waveform.

SPWM is an effective way to produce a sinusoidal output from a DC source, and it is a fundamental technique in applications where precise control of the output waveform is necessary. It helps reduce harmonics, improve efficiency, and minimize unwanted electromagnetic interference.

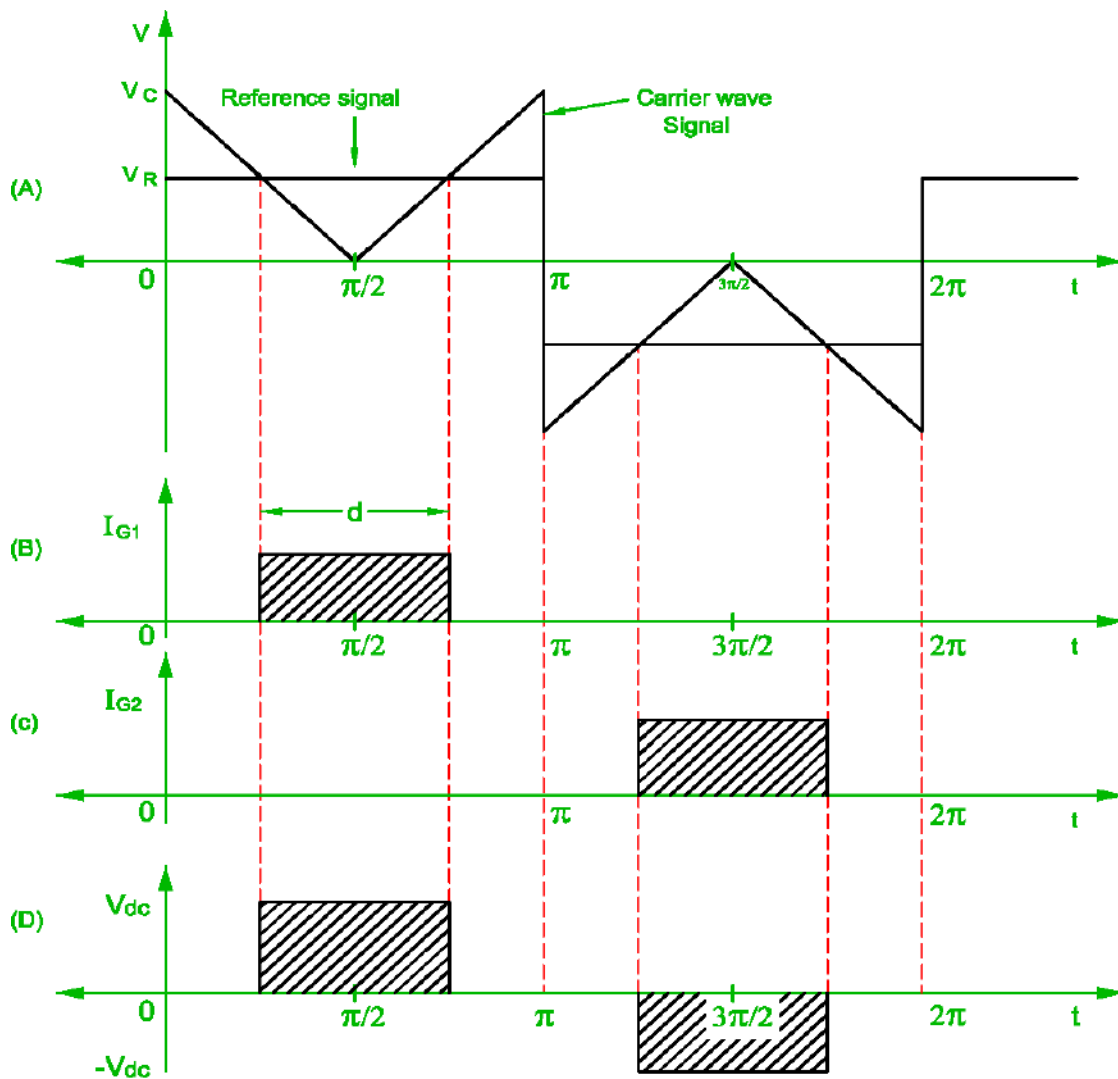

FIG H : SINGLE PULSE WIDTH MODULATION

Multiple Pulse Width Modulation:

Multiple Pulse Width Modulation (MPWM) is a modulation technique used in power electronics to control the output voltage or current of an inverter. It is an extension of the basic Pulse Width Modulation (PWM) technique and is commonly employed in applications like motor control, renewable energy systems, and variable frequency drives (VFDs). MPWM allows for more than one pulse per half-cycle of the output waveform, providing finer control over the output.

Here's how MPWM works:

1. **Reference Signal:** Like in SPWM, you start with a reference signal, typically a sinusoidal waveform, which represents the desired output. The frequency and amplitude of the reference signal are predetermined.
2. **Comparison:** The reference signal is compared with a carrier signal, which has a much higher frequency compared to the reference signal. This carrier signal is typically a high-frequency triangular waveform or a high-frequency square wave.
3. **Pulse Generation:** The comparison between the reference signal and the carrier signal generates a series of pulses. In MPWM, you have multiple pulses within each half-cycle of the reference signal. The number of pulses can be adjusted, and the pulse widths are varied based on the instantaneous value of the reference signal concerning the carrier signal. This results in a sequence of pulses that encode the desired waveform.
4. **Gate Control:** These pulses are then used to control the switching of semiconductor devices (such as transistors or IGBTs) in the inverter circuit. The pulse widths and positions determine when and how long these devices are turned on during each half-cycle of the output waveform.
5. **Output Generation:** The switching of these devices creates an approximation of the desired waveform. The more pulses you have in each half-cycle and the more precise you control their widths and positions, the closer the approximation to the desired waveform. This fine control reduces harmonic distortion and can provide smoother and more precise voltage or current output.

MPWM offers greater flexibility and control over the output waveform compared to traditional SPWM. By manipulating the number and position of the pulses in each half-cycle, it is possible to closely match the reference signal and reduce distortion in the output waveform. This makes MPWM particularly useful in applications where high-quality and precise control of the output is required.

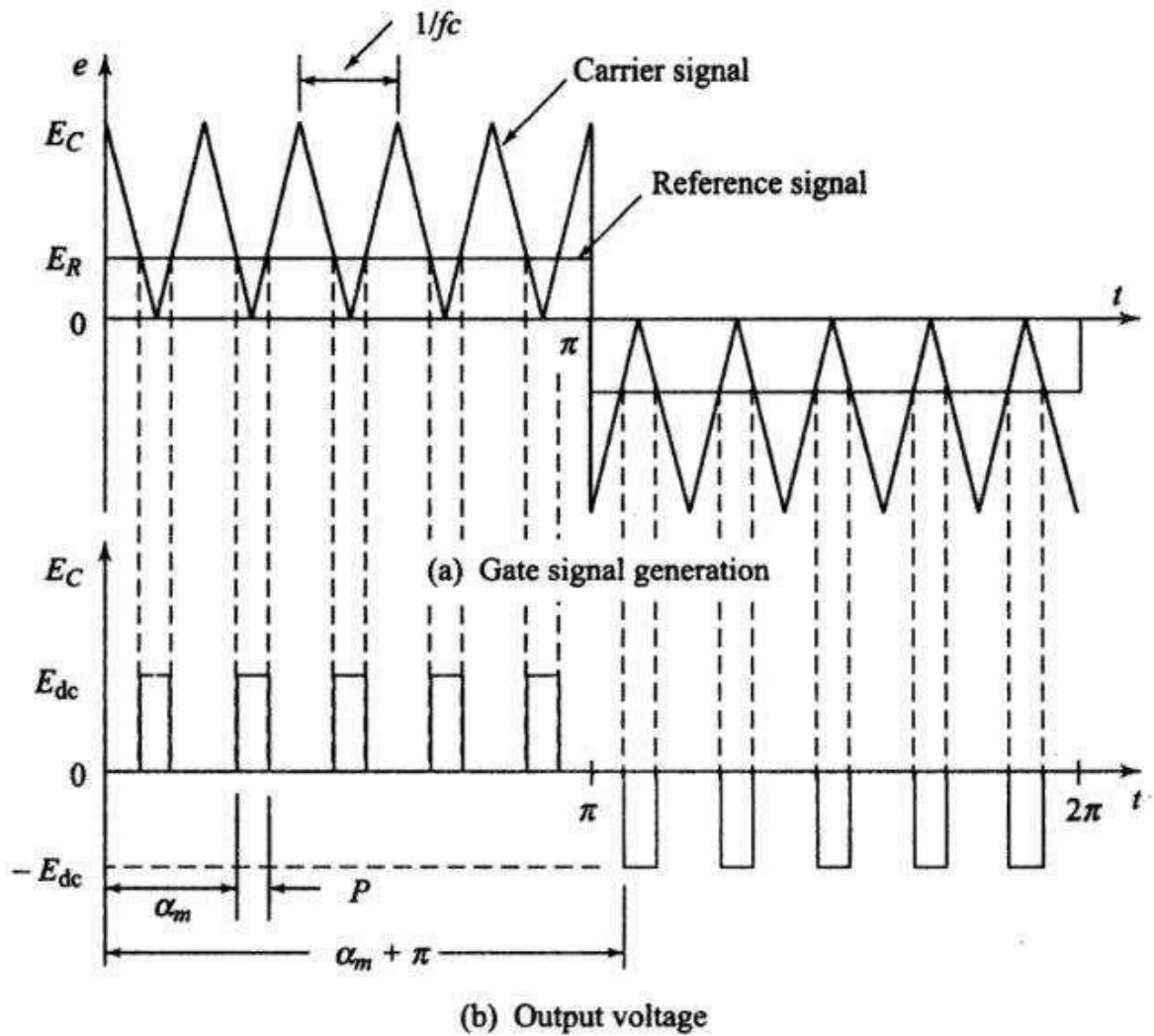

Fig.1 Multiple-pulse width modulation

SINUSOIDAL PULSE WIDTH MODULATION:

In Sinusoidal Pulse Width Modulation, the pulse-width instead of being uniform as in the waveform of Fig. 11.55 is a sinusoidal function of its angular position with respect to a reference sine wave resulting in a reduction in the harmonic content. The control function consists of a sinusoidal wave obtained from an oscillator of variable amplitude A and of fundamental output inverter frequency $f = 1/T$ as well as a triangular wave of fixed amplitude A_p and frequency f_p with a direct component of amplitude A_p as shown in Fig.

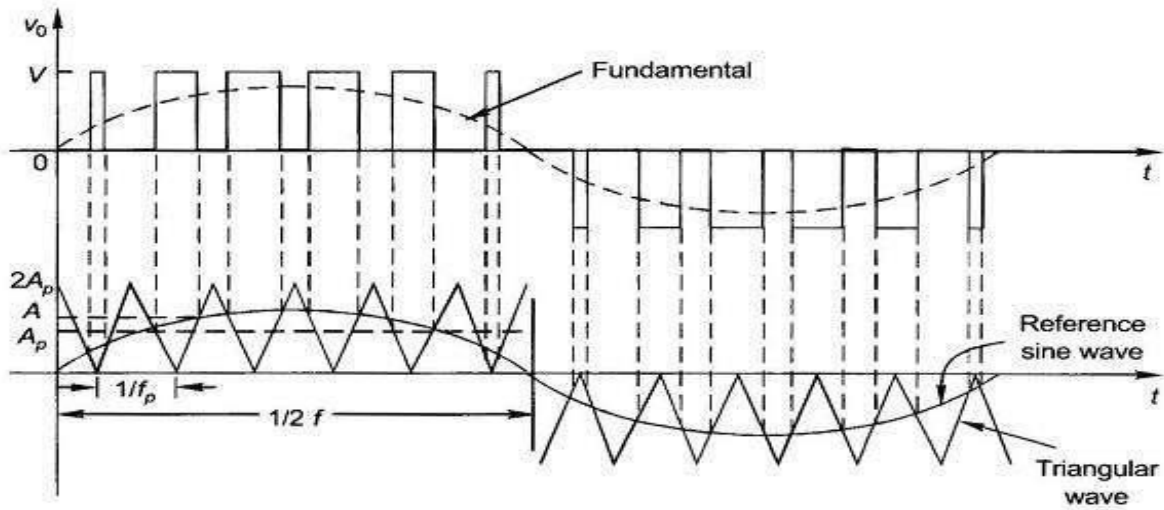

Fig. 11.56 Output voltage with sinusoidal pulse modulation

The biased triangular waveform is reversed in polarity at the end of each half-cycle of the output voltage. Pulsed gating signals are generated by comparison of the sinusoidal and triangular waveforms—gating pulses are obtained for time intervals in which the sinusoidal signal is more positive than the triangular signal.

It is easily established from the figure that the number of gate pulses (sinusoidally modulated) per half-cycle is

$$N = \frac{f_p}{2f} = \text{integer} \quad (11.26)$$

It follows from the above that the angles for turn-on and commutation of the thyristors are determined by the intersections of the two above referred signals. It can be easily seen from Fig. 11.56 that the amplitude of the fundamental voltage can be controlled by varying amplitude A of the sine wave over the range $0 < A < A_{\max}$ where $A_{\max} = 2A_p$. If A is made larger than A_{\max} , the number of output pulses becomes less than N (Eq. (11.26)). In the limit the output becomes a single rectangular pulse of half-cycle width as in the case of ordinary (unmodulated) bridge inverter.

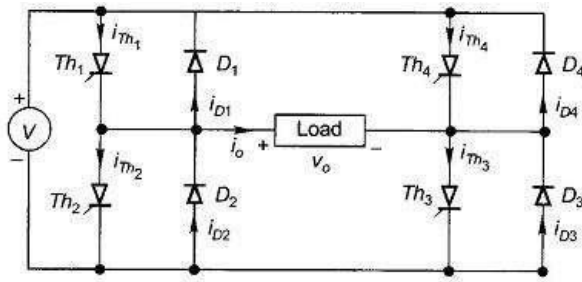

Fig. 11.48(a)

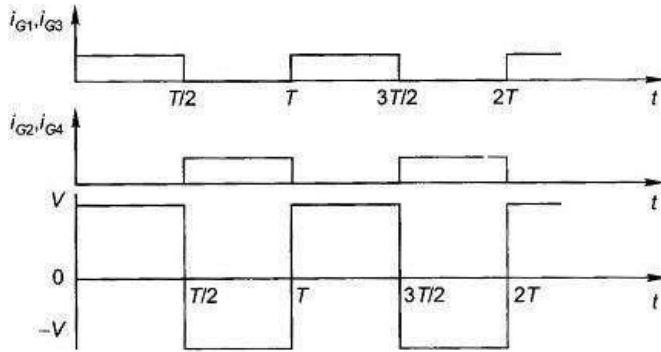

Fig. 11.48(b) Single-phase bridge inverter

The gating signals obtained as the above are employed to fire the thyristors in the bridge inverter of Fig. 11.48. Thyristors Th_1 and Th_3 are gated during the interval of a positive pulse and Th_2 and Th_4 are gated during the negative pulse. During the zero-value intervals of the pulsed-gating signals Th_1 and Th_4 or Th_2 and Th_3 are gated resulting in zero output voltage. Thus, the output voltage as shown in Fig. 11.56 is a replica of the pulsed-gating signals generated by comparison of sinusoidal and triangular waveforms fed to the commutating circuitry.

Examination of the circuit of the half-bridge inverter of Fig. 11.46(a) reveals that there is no way in which the load voltage can be reduced to zero. At all times, $v_o = \pm V_{dc}/2$. The above method of Sinusoidal Pulse Width Modulation, therefore, cannot be applied as such. A modified method of modulation that can be employed in the half-bridge inverter is illustrated in Fig. 11.57. Voltage control is achieved by varying the amplitude of the reference sine wave. This type of voltage control is rarely employed because of its high ratio of harmonic amplitudes to the amplitude of the fundamental component of the output voltage wave.

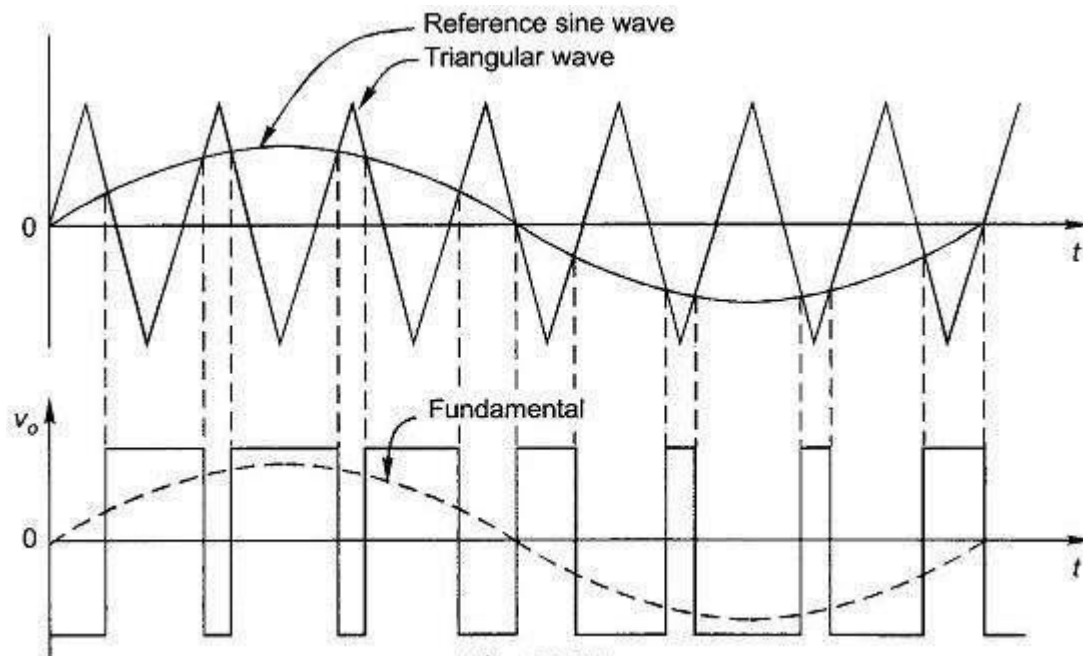

Fig. 11.57

The use of a pulse-width modulated (PWM) inverter for ac motor control is illustrated in Fig. 11.54 where the inverter is fed from a substantially constant dc voltage diode rectifier, while the control of ac voltage at motor terminals is achieved through the inverter.

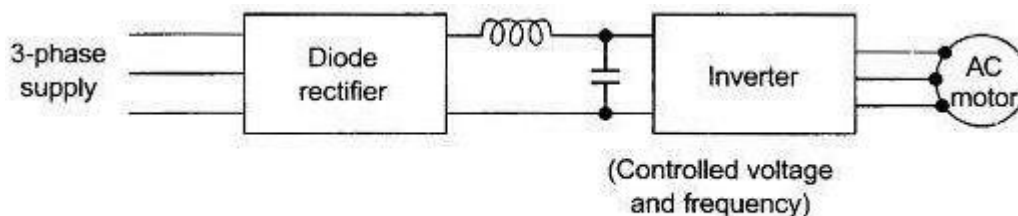

Fig. 11.54

The chief advantage of this scheme of control lies in the fact that it requires a single controllable power conversion so that the power factor of ac supply to the diode rectifier is high. Further, the low-frequency harmonic content of the PWM inverter is lower than that of an ordinary (unmodulated inverter). These advantages of the PWM drive are obtained at the cost of greater sophistication in the control logic. In PWM drive the inverter efficiency is somewhat decreased because of many commutations per half-cycle. The commutation frequency should be increased as permitted by the devices so as to obtain a good balance between increase in inverter loss and decrease of machine loss (due to reduced harmonic content).

SPACE VECTOR MODULATION FOR TWO-LEVEL INVERTERS

ACTIVE AND ZERO SPACE VECTORS

Space vector modulation is an alternative to the Carrier-Based modulation technique that is used in the Three-phase Voltage Source Inverter (VSI) application note. Both methods are similar, in the sense that they transform a reference voltage into switching signals

for the inverter. However, SVM operates in the Clarke referential ($\alpha\beta$) rather than the abc one [1]. The topology of a two-level three-phase inverter is presented in the figure below.

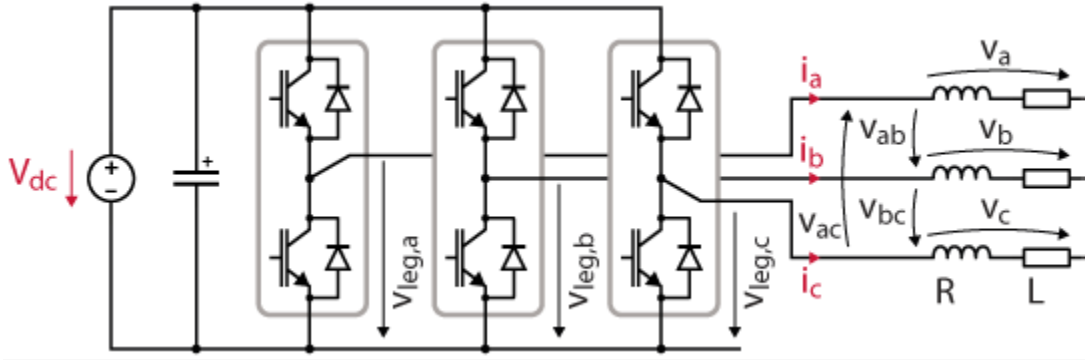

Topology of a two-level inverter with an RL load

In the $\alpha\beta$ frame, each switching state of the inverter is represented by a space vector. Then, since the DC bus should not be short-circuited, the upper and lower switches of each leg must operate in a complementary way. As such, there are only eight possible switching states for the inverter. In this note, the state of a leg is “1” if the upper switch is conducting, and “0” if the lower switch is conducting.

The eight possible space vectors are summarized in the table below: V_0 and V_7 are called zero space vectors as they do not produce any phase voltage. By contrast, V_1 to V_6 produce non-zero phase voltages and are called active space vectors.

SPACE VECTOR	STATE LEG A	STATE LEG B	STATE LEG C	V_A	V_B	V_C
V_0	0	0	0	0	0	0
V_1	1	0	0	$2 V_{DC}/3$	$-V_{DC}/3$	$-V_{DC}/3$
V_2	1	1	0	$V_{DC}/3$	$V_{DC}/3$	$-2 V_{DC}/3$
V_3	0	1	0	$V_{DC}/3$	$2 V_{DC}/3$	$-V_{DC}/3$
V_4	0	1	1	$-2 V_{DC}/3$	$V_{DC}/3$	$V_{DC}/3$
V_5	0	0	1	$-V_{DC}/3$	$-V_{DC}/3$	$2 V_{DC}/3$
V_6	1	0	1	$V_{DC}/3$	$-2 V_{DC}/3$	$V_{DC}/3$
V_7	1	1	1	0	0	0

Possible switching states of the inverter with the corresponding phase voltages

VOLTAGE SYNTHESIS WITH SPACE VECTOR MODULATION

The space vector modulation method has only eight space vectors at its disposal. However, other space vectors can be synthesized – on average – by alternating several active and zero vectors over a switching period of the modulator. For example, the active vectors V_1 and V_2 can be used to synthesize a reference space vector with an angle between 0 and 60° – see the figure below – while the zero vectors V_0 and V_7 allow reducing the amplitude of this reference vector.

When synthesizing a space vector with SVM, the feasible space in the $\alpha\beta$ plane is a hexagon, as shown in the figure below. Then, the active space vectors divide the hexagon into six triangular sectors. In the first sector, the active vectors V_1 and V_2 are used.

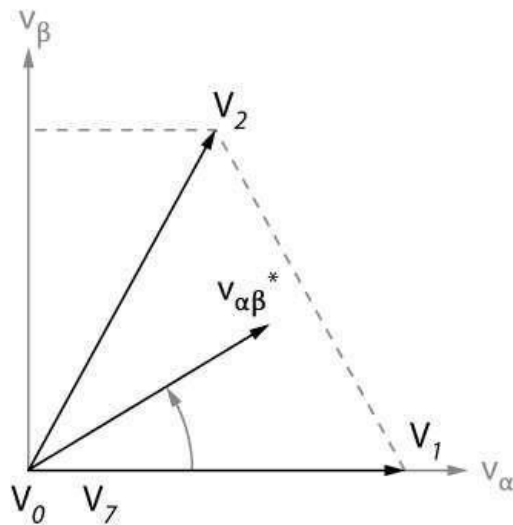

Synthesis of a reference space vector with the active vectors V_1 and V_2 , and the zero vectors V_0 and V_7

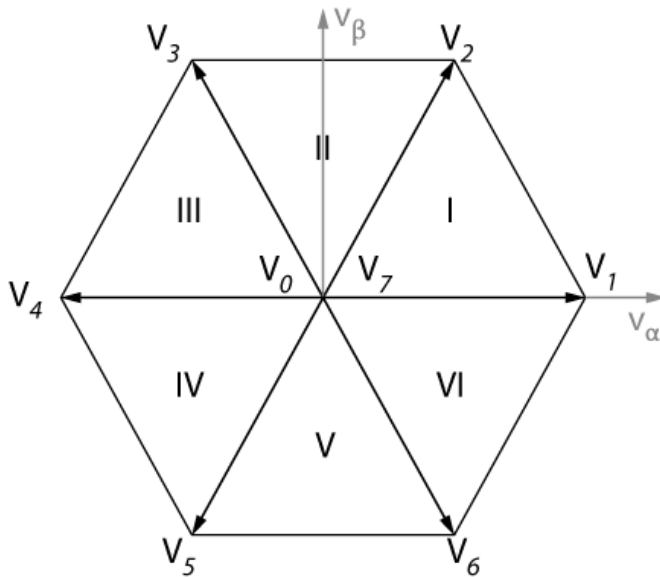

Representation of the active and zero space vectors in the $\alpha\beta$ plane, and division in six sectors

The SV-PWM modulator from imperix libraries will automatically select the appropriate active vectors and choose the dwell times, based on the angle and the amplitude of the input reference space vector. The switching sequence is then made symmetrical in order to minimize switching losses. The figures below illustrate how the same active and zero space vectors can produce different switching patterns (or PWM signals) for sector I, which are either optimal or sub-optimal in terms of switching losses.

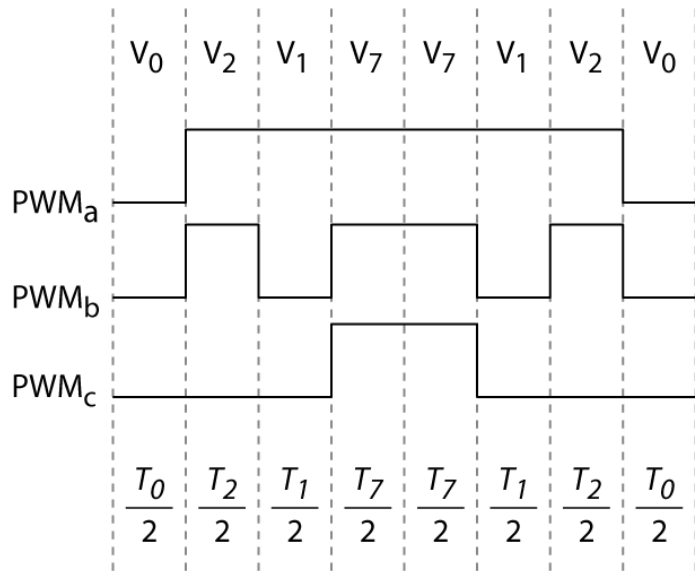
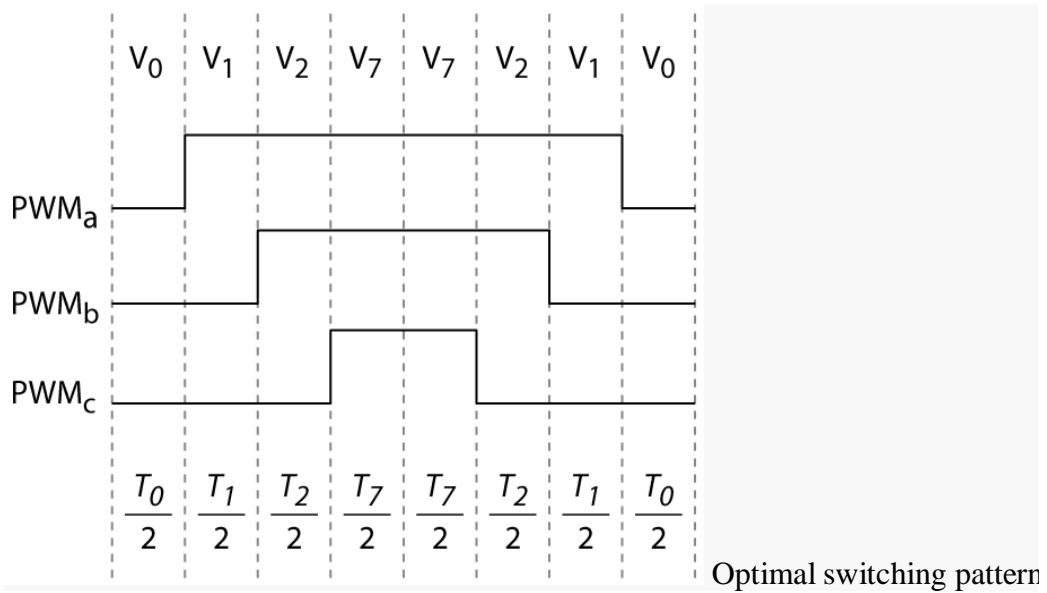

Sub-optimal switching patterns

For reference, the optimal switching patterns for each sector are presented in the next figure.

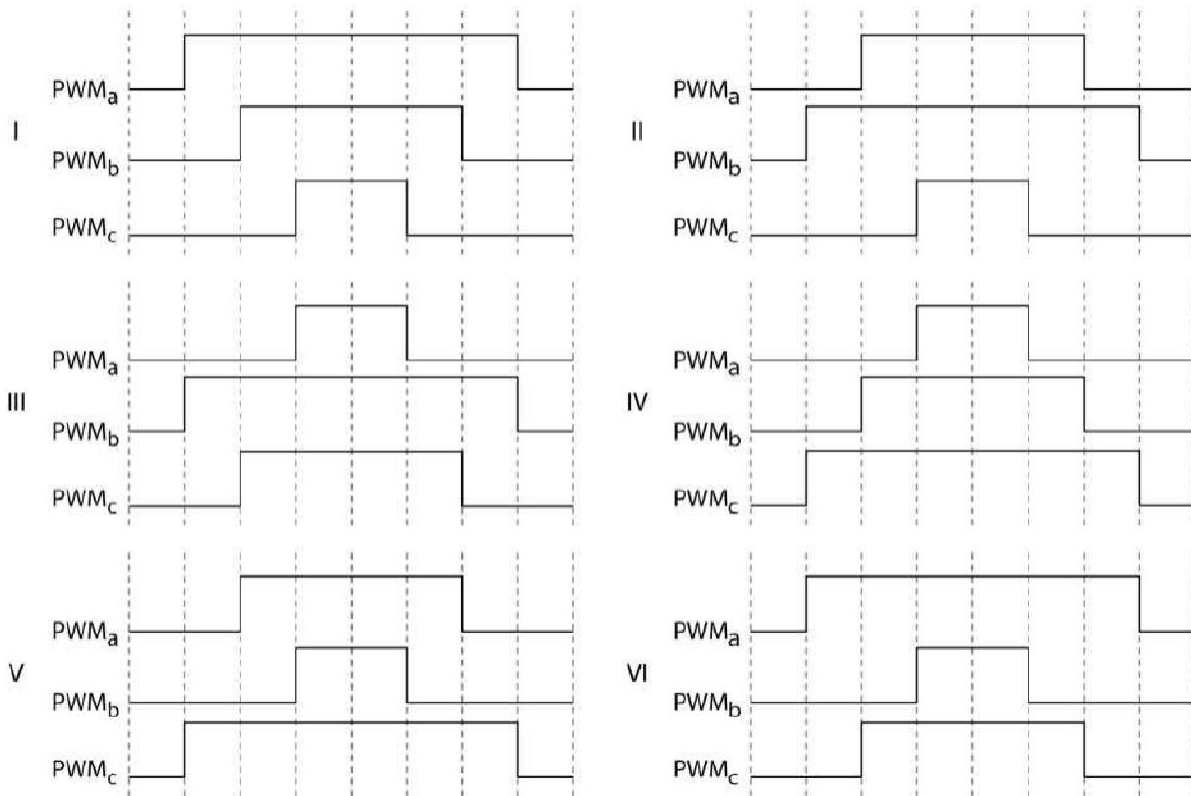

Optimal switching patterns for each sector

SPACE VECTOR MODULATION FOR THREE-LEVEL INVERTERS

The space vector modulation technique for two-level inverters can be generalized to three levels [2]. A three-level converter has three possible switching states per leg, denoted P (positive output voltage), N (negative output voltage), and 0 (zero output). In total, the converter has 27 possible switching states. NPC inverters are a typical example of three-level converters (see the topology below).

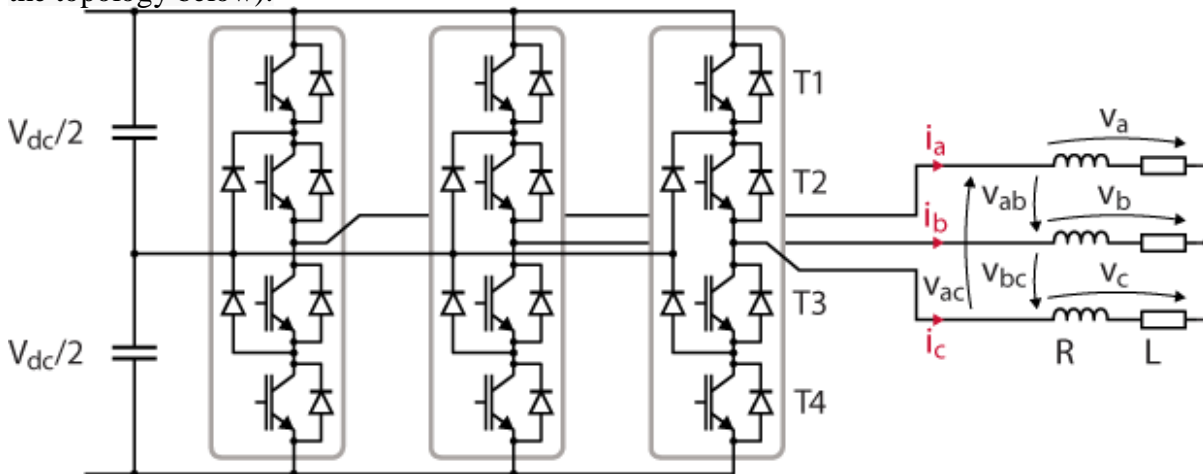

Topology of a three-level Neutral Point Clamp (NPC) inverter with an RL load

As for the two-level inverter, each switching state is represented by a space vector in the Clarke referential. Similarly, the feasible space in the Clarke referential is also a hexagon, as shown below. In terms of voltage synthesis, a three-level converter has more degrees of freedom, since it has more space vectors at disposal. Nevertheless, the same basic concept as

before applies: look for the closest active and zero vectors, and alternate between them to produce the reference space vector on average.

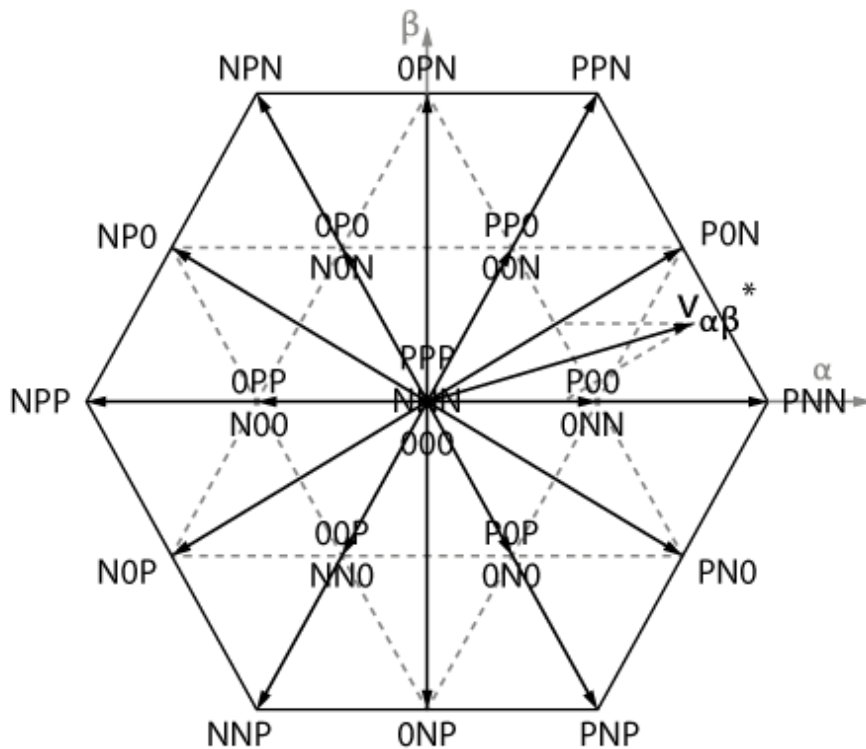

Representation of the active and zero space vectors in the $\alpha\beta$ plane for an NPC converter

In order to find appropriate active and zero vectors to apply, the SV-PWM modulator from imperix libraries uses a hexagonal coordinate system, as presented in [2], rather than a division in six sectors. While the search method differs from the two-level variant of the algorithm, switching patterns are constructed with the same logic: commutations are avoided as much as possible to limit switching losses. The figure below illustrates an example of an optimal switching pattern generated by a three-level converter.

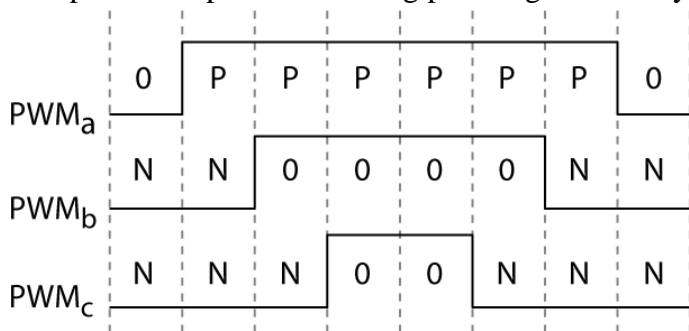

Example of optimal switching pattern with three levels

REDUCTION OF HARMONICS IN OUTPUT VOLTAGE OF INVERTER INTRODUCTION

Inverters are most important power electronic equipment which is being used for various purposes such as variable speed AC drive (VSD), uninterrupted power supplies (UPS), Static

frequency changer (SFC), etc. Among them VSD continues to be the fastest growing application.

Voltage source inverter and current source inverter. A voltage fed inverter is one in which the DC source has small or negligible impedance. In other words, a voltage source inverter has a stiff voltage source at its input terminals. A current fed inverter (CFI) or current source inverter (CSI) is fed with adjustable current from a DC source of high impedance, i.e. from a stiff DC current source.

Voltage source inverters are generally classified into two types viz pulse width modulation and square wave. These inverters are introduced in early 1960s during the introduction of force commutating techniques. The major disadvantage of this inverter is that the output voltage contains lower order harmonics for low or medium power applications. And lower order harmonics create a lot of distortion and are hard to eliminate. The type of driver has been largely superseded by recent development in pulse width modulation drives and there have been number of clear trends in the development of PWM concepts, strategies and methodology since 1970s. In the mid of 1980s a form of PWM called space vector modulation (SVM) was proposed which claimed to offer significant advantages over conventional and simple regular pulse width modulation in term of ease of application, maximum transfer ratio and in term of performance.

Recent developments in semiconductor material, technologies and power electronics have brought significant improvement in power electronics system. Hence different circuit configurations, namely multilevel inverters have become popular and considerable interested by researcher are given to them due to increased efficiency and performance.

Inverters play important role in the field of power electronics. The inverters in the power electronics domain denote a class of power conversion circuits which is required for converting from one source to other either from DC to AC and vice-versa depending upon the source given to the circuit.

These level voltages fed PMW inverters are recently showing the popularity for multi megawatt industrial drive applications. The main reason for this popularity is that the output voltage waveforms in multilevel inverters can be generated at low switching frequencies with high efficiency and low distortion and large voltage between the series drive sis easily shared. Space vector PWM techniques are one of the most popular techniques gained interest recently. This technique results in higher magnitude of the fundamental output available compared to sinusoidal PWM.

The organization of the paper is as follows: next section discusses the Lag Compensator followed by the discussion of its design procedure in the third section. In the fourth section simulation results are presented and in the last section presents the conclusion of the work.

HARMONICS IN ELECTRICAL SYSTEM

One of the biggest problems in the power quality aspects is the harmonic contents in the electrical system. Harmonics are the distortion of the normal electrical current waveform,

generally transmitted by non linear loads. Example of nonlinear loads- switched mode power supplies, variable speed motors and drives, photocopiers, etc.

Fig. 1. Harmonics in electrical waveforms

Electronic harmonic currents generated by non linear loads increases heat losses and power bills of end users. These harmonics related losses reduces system efficiency, causes apparatus overheating, and power and air conditioning costs. As the number of harmonics producing loads have increased in the recent year, it has become necessary to address their influence during addition or changes to an installation. Harmonic currents can have significant impact on the electrical distribution system and the facilities they feed. Distortion travels back into the power source and can affect other equipment connected to the same source. Generally harmonics are divided into two types: 1. voltage harmonics 2. Current harmonics.

Current harmonics are usually generated by harmonics contained in voltage supply and depends on the type of load such as resistive load, capacitive load and inductive load. Both harmonics can be generated either the source or load side.

Fig. 2. Distorted waveform and harmonics component

REDUCTION OF HARMONICS IN INVERTER OUTPUT VOLTAGE

There are several industrial applications which may allow a harmonic content of 5% of its fundamental component of input voltage . The harmonic content can be brought to a reasonable limit of 5 % by one of the methods, by inserting filters between the load and inverter. If there is a high frequency harmonics, these can be reduced by a low size filter. But for the attenuation of low frequency harmonics, size of filter components increases and it makes the filter bulky, costly, weighty and additionally sluggish transient response of the system .

HARMONIC FILTER:

High frequency harmonics can be reduced to a reasonable limit by using filters. The following are the normally used filters:

LC FILTER

It consists of L and C component. The L offers a high impedance to harmonic voltage, higher the harmonic number, higher will be impedance and lower will magnitude of the harmonic at the output . The C offers a shunt path for the harmonic current .As the impedance of the Capacitor will decrease, increases frequency and it in turn increases the impedance of the inductor.

OTT FILTER

It is used extremely in conjunction with parallel inverter It performs three important functions . It provides a sine wave output thus leads elimination of harmonic content to the load. It provides good load regulation while at the same time maintaining a capacitive load to the inverter over a large range of load power factor.

RESONANT ARM FILTER

The output voltage of the inverter will have a certain harmonic content, however, an approximately sinusoidal output may be required. A sinusoidal output voltage can be realized by means of a combined series parallel resonant filter circuit tuned to the fundamental of the output voltage. The sinusoidal output current driven by the sinusoidal output voltage will give rise to an AC component on the DC side of the inverter and therefore it will augment the ripple in the input current.

HARMONIC REDUCTION BY PWM:

In the case of single pulse width modulation, the pulse width is adjusted to reduce the harmonics. It has one of the disadvantages of additional commutation per cycle and this leads to more switching losses in the thyristor.

HARMONIC REDUCTION BY TRANSFORMER CONNECTION

The harmonic content of output voltage can be reduced by the output voltage from two or more inverters, can be combined by means of transformer. The essential condition of this scheme is that the output voltage waveform from inverter must be similar but phase shifted from each other. In this scheme, transformer has 1:1 turn ratio. It has disadvantage that it needs more number of inverters of transformer of similar rating.

USING STEPPED WAVE INVERTER :

This method of reduction of harmonic is also known as stepped wave inverter, in which pulses of different widths and heights are added to produce a resultant stepped wave with reduced harmonic content. Two stepped wave inverters fed from a common DC supply. Both the transformers used have different turn ratio. The turn ratio from primary to secondary is assumed 3:1 for transformer 1 and transformer 2. The inverter 1 is so gated that its output voltage is positive. During half cycle, output voltage level is either zero or positive. During half cycle, the output voltage would be either zero or negative. This output voltage waveform is named as two level modulation. The output voltage of inverter 2 is negative. The waveform of inverter 2 shows that the output voltage is positive, negative or zero during the half cycle, it is named three level modulation. By superimposing the outputs of both inverters the resultant output voltage from a series combination of inverter 1 and inverter 2 is obtained.

PWM TECHNIQUES:

The output voltage of an inverter can also be controlled by providing a control within the inverter itself. The most efficient methods of doing this is by pulse width modulation control used within an inverter. In this method a fixed DC input voltage is given to the inverter and a controlled AC output voltage is obtained by adjusting the on and off periods of the inverter components. This is the most popular method of controlling the output voltage and this method is termed as pulse width modulation control.

CURRENT SOURCE INVERTER:

The current source inverter is also known as current fed inverter which converts the input dc into ac and its output can be three-phase or single phase. According to the definition of the current source, an ideal current source is the kind of source in which current is constant and it is independent of voltage.

CURRENT SOURCE INVERTER CONTROL

The voltage source is connected in series with a large value of inductance (L_d) and this named the circuit as the current source. The circuit diagram of the current source inverter fed induction motor drive is shown in the below figure.

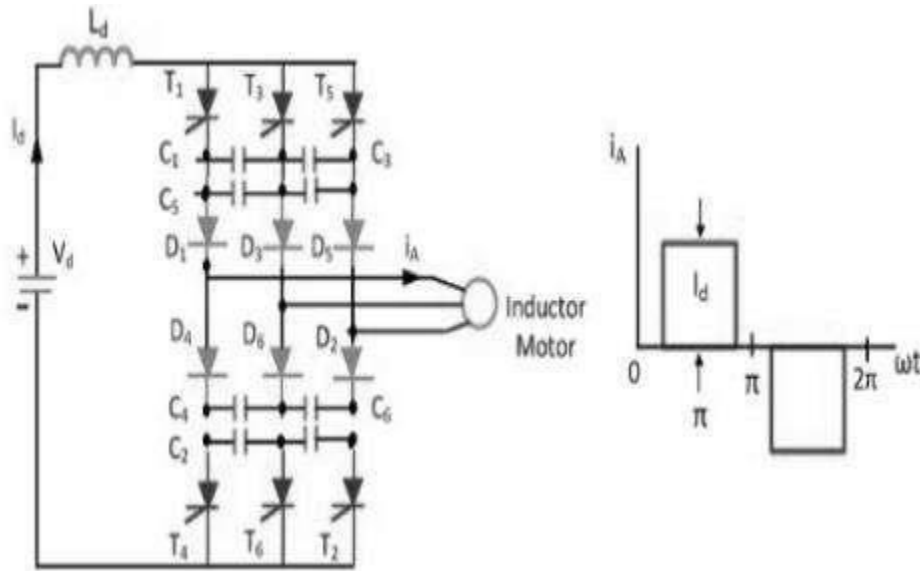

The circuit consists of six diodes ($D_1, D_2, D_3, D_4, D_5, D_6$), six capacitors ($C_1, C_2, C_3, C_4, C_5, C_6$), six thyristors ($T_1, T_2, T_3, T_4, T_5, T_6$) which are fixed with a phase difference of 60° . The inverter output is connected to the induction motor. For a given speed, torque is controlled by varying the dc-link current I_d and this current can be varied by varying the V_d . The conduction of two switches in the same leg doesn't lead to a sudden rise of current due to the presence of a large value of inductance L_d .

The configurations of current source inverter fed inductor motor drive depending upon the source are shown in the below figure.

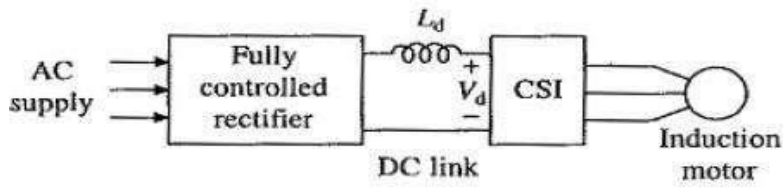

(a)

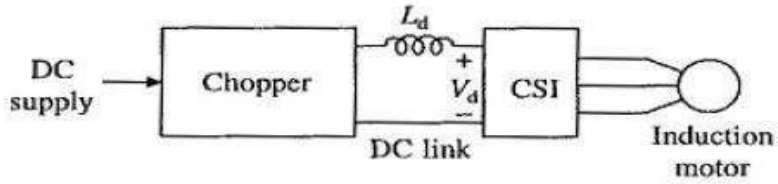

(b)

CSI Induction Motor Drives

When the source is available in dc source, the chopper is used to vary the current. When the source is available in ac source then there fully controlled rectifier is used to vary the output current.

UNIT-III

UNCONTROLLED RECTIFIERS

POWER DIODE:

A diode that has two terminals like anode & cathode and two layers like P & N, used in the power electronics circuits is known as power diode. This diode is more complex in construction as well as in operation because low power device has to change to make them appropriate in high power applications.

In power electronic circuits, this diode plays an essential role. It can be used as a rectifier in converter circuits, voltage regulation circuits, flyback / freewheeling diode, reverse voltage protection, etc.

These diodes are related to signal diodes except for a slight disparity in its construction. The doping level in signal diode for both P-layer & N-layer is the same whereas, in power diodes, the junction can be formed among a heavily doped P+ layer & lightly doped N- layer.

CONSTRUCTION

The construction of this diode includes three layers like the P+ layer, n- layer and n+ layer. Here the top layer is the P+ layer, it is heavily doped. The middle layer is n- layer, it is lightly doped and the last layer is n+ layer, and it is heavily doped.

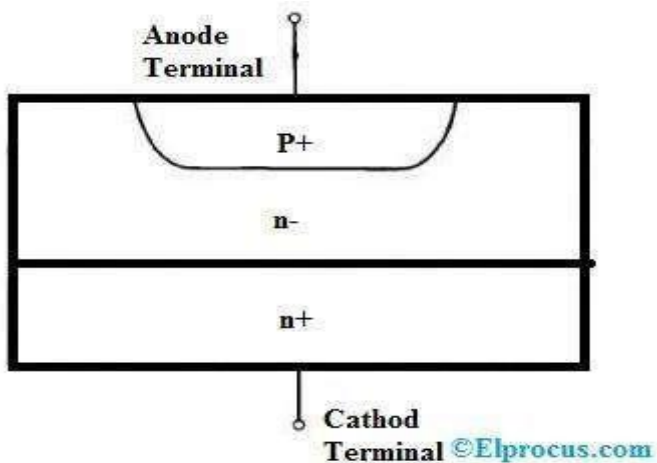

power-diode-construction

Here p+ layer acts as an anode, the thickness of this layer is 10 μm & the level of doping is 10^{19} cm^{-3} .

The n+ layer acts as a cathode, the thickness of this layer is 250-300 μm & the level of doping is 10^{19} cm^{-3} .

The n- layer acts as a middle layer/drift layer, the thickness of this layer mainly depends on the breakdown voltage & the level of doping is 10^{14} cm^{-3} . Once this layer width increases then breakdown voltage will be increased.

WORKING PRINCIPLE OF POWER DIODE

The working principle of this diode is similar to the normal PN junction diode. When the voltage of the anode terminal is high than the voltage of the cathode terminal, the diode conducts. The range of forwarding voltage drop in this diode is very small approximately 0.5V – 1.2V. In this mode, the diode works as a forward characteristic.

If the voltage of the cathode is high than the voltage of anode, the diode performs as blocking mode. In this mode, the diode performs like the reverse characteristic.

TYPES OF POWER DIODE

The classification of these diodes can be done based on the reverse recovery time, the process of manufacturing & the depletion region penetration in reversed bias condition.

The power diodes depending on the reverse recovery time as well as the process of manufacturing are classified into three types such as

- General Purpose Diodes
- Fast Recovery Diodes
- Schottky Diodes

GENERAL PURPOSE DIODES

These diodes have huge reverse recovery time around 25 μ s; therefore they are applicable in low frequency (up to 1 kHz) & low-speed operations (up to 1- kHz).

FAST RECOVERY DIODES

These diodes have quick recovery act due to their very small reverse recovery time less than 5 μ s, used in high-speed switching applications

SCHOTTKY DIODES

Please refer to this [link](#) to know more about Schottky diodes

HALF WAVE RECTIFICATION

A rectifier is a circuit which converts the Alternating Current (AC) input power into a Direct Current (DC) output power. The input power supply may be either a single-phase or a multi-phase supply with the simplest of all the rectifier circuits being that of the **Half Wave Rectifier**.

The power diode in a half wave rectifier circuit passes just one half of each complete sine wave of the AC supply in order to convert it into a DC supply. Then

this type of circuit is called a “half-wave” rectifier because it passes only half of the incoming AC power supply as shown below.

HALF WAVE RECTIFIER CIRCUIT

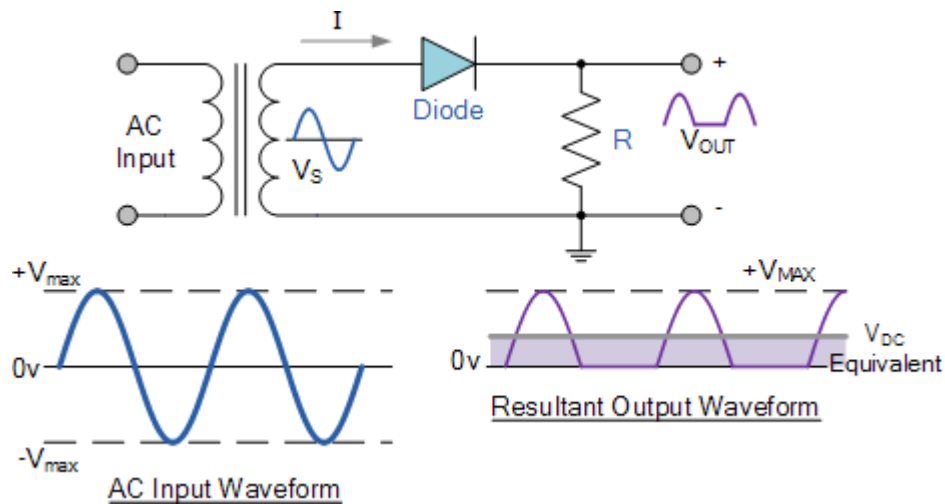

During each “positive” half cycle of the AC sine wave, the diode is forward biased as the anode is positive with respect to the cathode resulting in current flowing through the diode.

Since the DC load is resistive (resistor, R), the current flowing in the load resistor is therefore proportional to the voltage (Ohm’s Law), and the voltage across the load resistor will therefore be the same as the supply voltage, V_s (minus V_f), that is the “DC” voltage across the load is sinusoidal for the first half cycle only so $V_{out} = V_s$.

During each “negative” half cycle of the AC sinusoidal input waveform, the diode is reverse biased as the anode is negative with respect to the cathode. Therefore, NO current flows through the diode or circuit. Then in the negative half cycle of the supply, no current flows in the load resistor as no voltage appears across it so therefore, $V_{out} = 0$.

The current on the DC side of the circuit flows in one direction only making the circuit **Unidirectional**. As the load resistor receives from the diode a positive half of the waveform, zero volts, a positive half of the waveform, zero volts, etc, the value of this irregular voltage would be equal in value to an equivalent DC voltage of $0.318 \cdot V_{max}$ of the input sinusoidal waveform or $0.45 \cdot V_{rms}$ of the input sinusoidal waveform.

Then the equivalent DC voltage, V_{DC} across the load resistor is calculated as follows.

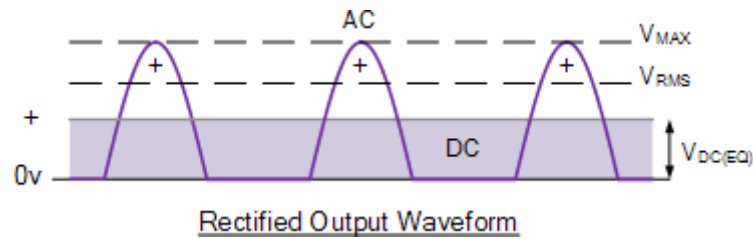

$$V_{d.c.} = \frac{V_{MAX}}{\pi} = 0.318V_{MAX} = 0.45V_{RMS}$$

Where V_{MAX} is the maximum or peak voltage value of the AC sinusoidal supply, and V_{RMS} is the RMS (Root Mean Squared) value of the supply voltage.

MID-POINT SECONDARY TRANSFORMER BASED FULL WAVE RECTIFIER:

A full wave rectifier is a type of rectifier which converts both half cycles of the AC signal into pulsating DC signal.

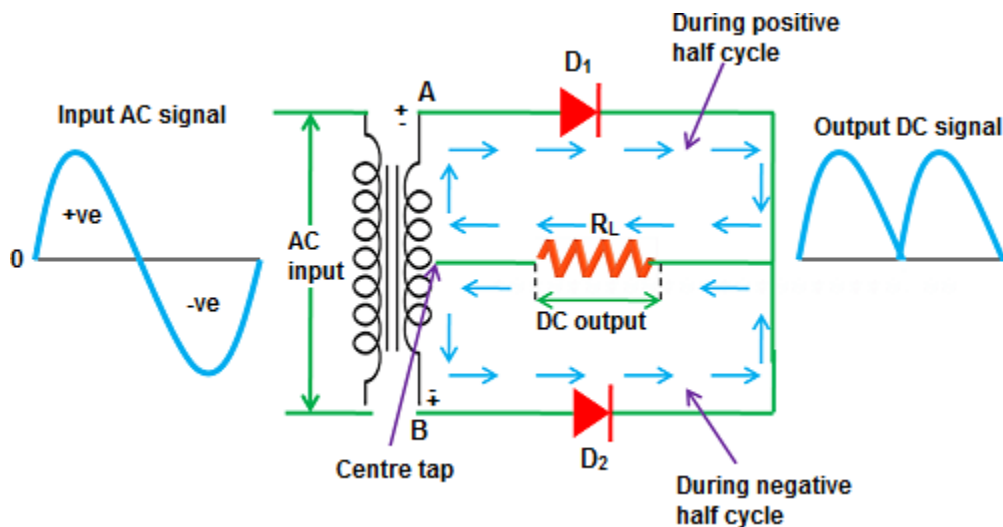

As shown in the above figure, the full wave rectifier converts both positive and negative half cycles of the input AC signal into output pulsating DC signal.

The full wave rectifier is further classified into two types: center tapped full wave rectifier and full wave bridge rectifier.

Before going to the working of a center tapped full wave rectifier, let's first take a look at the center tapped transformer. Because the center tapped transformer plays a key role in the center tapped full wave rectifier.

CENTER TAPPED TRANSFORMER

When an additional wire is connected across the exact middle of the secondary winding of a transformer, it is known as a center tapped transformer.

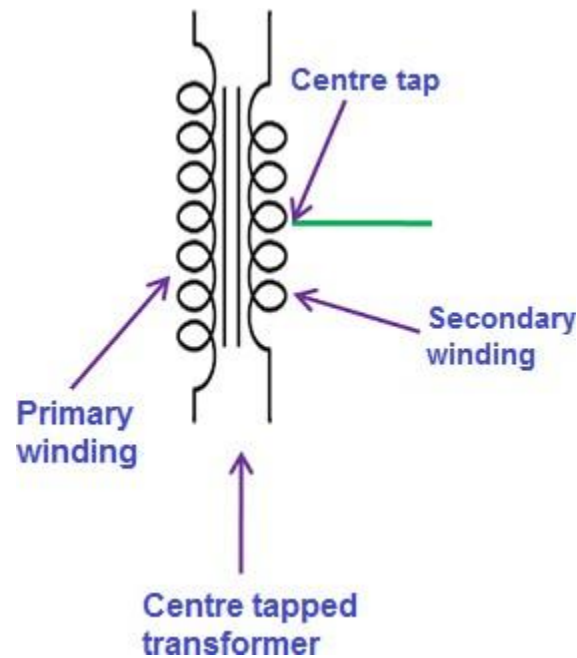

The wire is adjusted in such a way that it falls in the exact middle point of the secondary winding. So the wire is exactly at zero volts of the AC signal. This wire is known as the center tap.

The center tapped transformer works almost similar to a normal transformer. Like a normal transformer, the center tapped transformer also increases or reduces the AC voltage. However, a center tapped transformer has another important feature. That is the secondary winding of the center tapped transformer divides the input AC current or AC signal (V_P) into two parts.

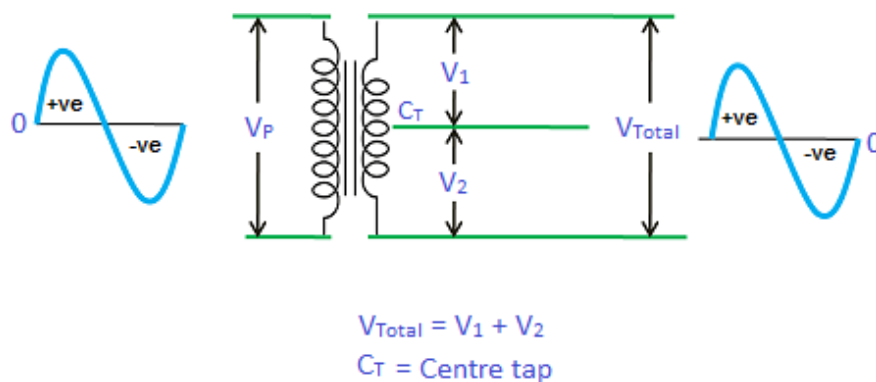

The upper part of the secondary winding produces a positive voltage V_1 and the lower part of the secondary winding produces a negative voltage V_2 . When we combine these two voltages at output load, we get a complete AC signal.

$$\text{I.e. } V_{\text{Total}} = V_1 + V_2$$

The voltages V_1 and V_2 are equal in magnitude but opposite in direction. That is the voltages (V_1 and V_2) produced by the upper part and lower part of the secondary winding are 180 degrees out of phase with each other. However, by using a full wave rectifier with center tapped transformer, we can produce the voltages that are in phase with each other. In simple words, by using a full wave rectifier with center tapped transformer, we can produce a current that flows only in single direction.

WHAT IS CENTER TAPPED FULL WAVE RECTIFIER

A center tapped full wave rectifier is a type of rectifier which uses a center tapped transformer and two diodes to convert the complete AC signal into DC signal.

The center tapped full wave rectifier is made up of an AC source, a center tapped transformer, two diodes, and a load resistor.

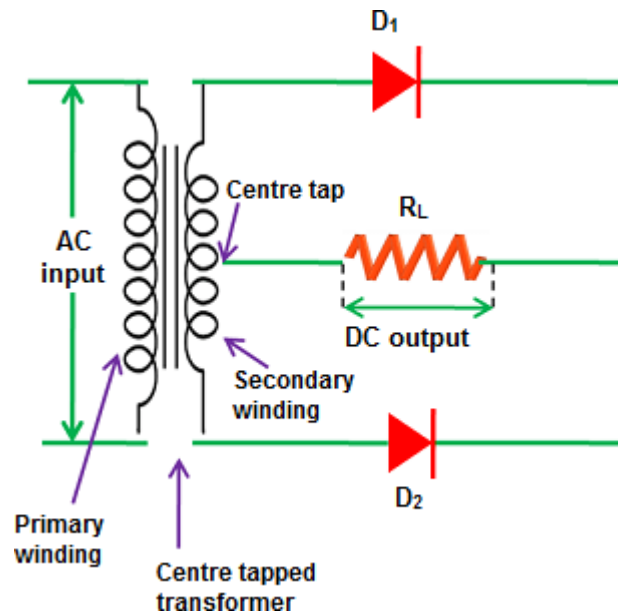

The AC source is connected to the primary winding of the center tapped transformer. A center tap (additional wire) connected at the exact middle of the secondary winding divides the input voltage into two parts.

The upper part of the secondary winding is connected to the diode D_1 and the lower part of the secondary winding is connected to the diode D_2 . Both diode D_1 and diode D_2 are connected to a common load R_L with the help of a center tap transformer. The center tap is generally considered as the ground point or the zero voltage reference point.

HOW CENTER TAPPED FULL WAVE RECTIFIER WORKS

The center tapped full wave rectifier uses a center tapped transformer to convert the input AC voltage into output DC voltage.

When input AC voltage is applied, the secondary winding of the center tapped transformer divides this input AC voltage into two parts: positive and negative.

During the positive half cycle of the input AC signal, terminal A become positive, terminal B become negative and center tap is grounded (zero volts). The positive terminal A is connected to the p-side of the diode D_1 and the negative terminal B is connected to the n-side of the diode D_1 . So the diode D_1 is forward biased during the positive half cycle and allows electric current through it.

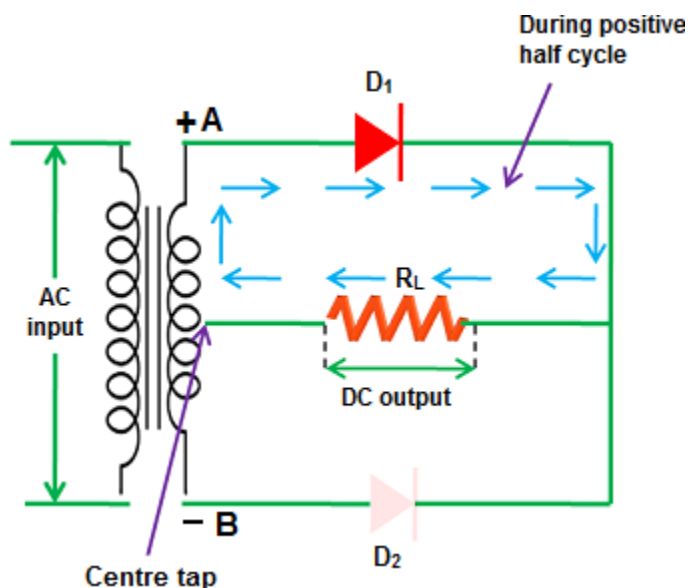

On the other hand, the negative terminal B is connected to the p-side of the diode D_2 and the positive terminal A is connected to the n-side of the diode D_2 . So the diode D_2 is reverse biased during the positive half cycle and does not allow electric current through it.

The diode D_1 supplies DC current to the load R_L . The DC current produced at the load R_L will return to the secondary winding through a center tap.

During the positive half cycle, current flows only in the upper part of the circuit while the lower part of the circuit carry no current to the load because the diode D_2 is reverse biased. Thus, during the positive half cycle of the input AC signal, only diode D_1 allows electric current while diode D_2 does not allow electric current.

During the negative half cycle of the input AC signal, terminal A become negative, terminal B become positive and center tap is grounded (zero volts). The negative terminal A is connected to the p-side of the diode D_1 and the positive terminal B is connected to the n-side of the diode D_1 . So the diode D_1 is reverse biased during the negative half cycle and does not allow electric current through it.

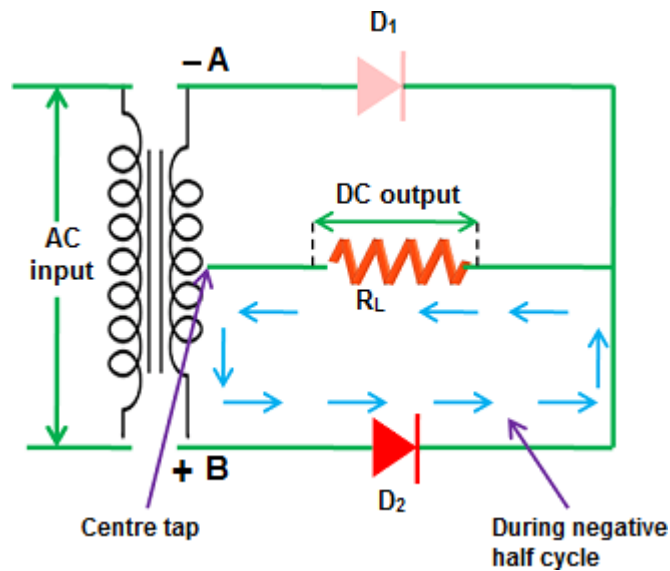

On the other hand, the positive terminal B is connected to the p-side of the diode D_2 and the negative terminal A is connected to the n-side of the diode D_2 . So the diode D_2 is forward biased during the negative half cycle and allows electric current through it.

The diode D_2 supplies DC current to the load R_L . The DC current produced at the load R_L will return to the secondary winding through a center tap.

During the negative half cycle, current flows only in the lower part of the circuit while the upper part of the circuit carry no current to the load because the diode D_1 is reverse biased. Thus, during the negative half cycle of the input AC signal, only diode D_2 allows electric current while diode D_1 does not allow electric current.

Thus, the diode D_1 allows electric current during the positive half cycle and diode D_2 allows electric current during the negative half cycle of the input AC signal. As a result, both half cycles (positive and negative) of the input AC signal are allowed. So the output DC voltage is almost equal to the input AC voltage.

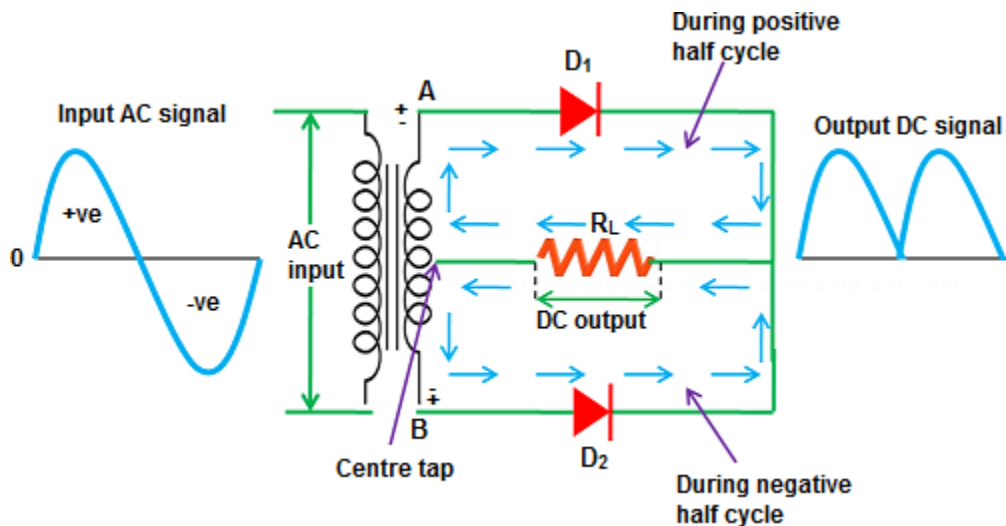

A small voltage is wasted at the diode D_1 and diode D_2 to make them conduct. However, this voltage is very small as compared to the voltage appeared at the output. So this voltage is neglected.

The diodes D_1 and D_2 are commonly connected to the load R_L . So the load current is the sum of individual diode currents.

We know that a diode allows electric current in only one direction. From the above diagram, we can see that both the diodes D_1 and D_2 are allowing current in the same direction.

We know that a current that flows in only single direction is called a direct current. So the resultant current at the output (load) is a direct current (DC). However, the direct current appeared at the output is not a pure direct current but a pulsating direct current.

The value of the pulsating direct current changes with respect to time. This is due to the ripples in the output signal. These ripples can be reduced by using filters such as capacitor and inductor.

The average output DC voltage across the load resistor is double that of the single half wave rectifier circuit.

OUTPUT WAVEFORMS OF FULL WAVE RECTIFIER

The output waveforms of the full wave rectifier is shown in the below figure.

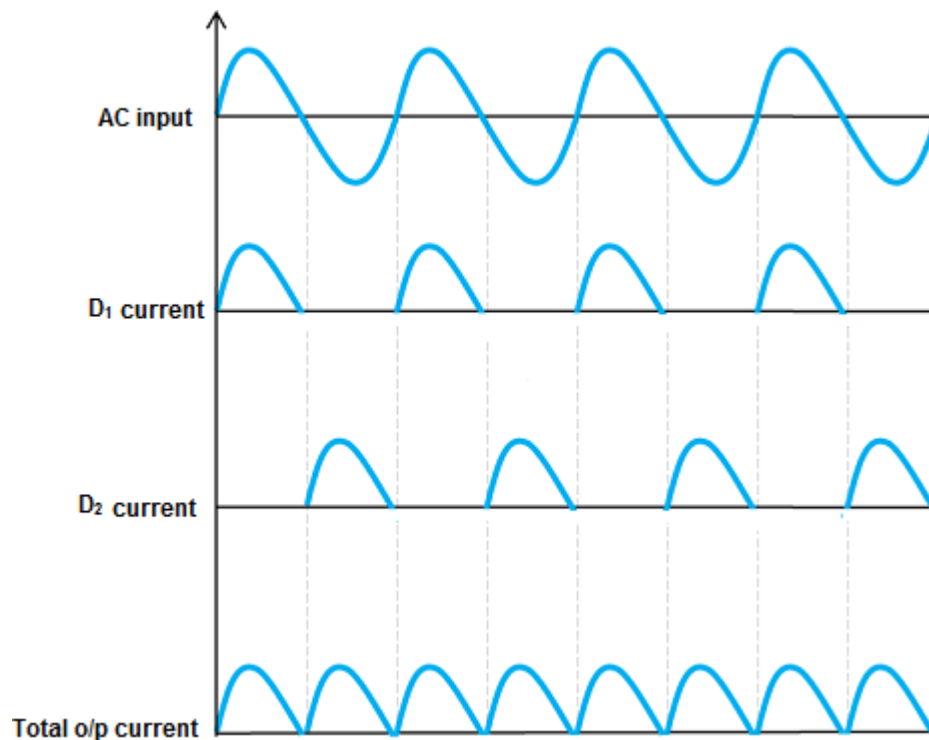

The first waveform represents an input AC signal. The second waveform and third waveform represents the DC signals or DC current produced by diode D_1 and diode D_2 . The last waveform represents the total output DC current produced by diodes D_1 and D_2 . From the

above waveforms, we can conclude that the output current produced at the load resistor is not a pure DC but a pulsating DC.

CHARACTERISTICS OF FULL WAVE RECTIFIER

RIPPLE FACTOR

The ripple factor is used to measure the amount of ripples present in the output DC signal. A high ripple factor indicates a high pulsating DC signal while a low ripple factor indicates a low pulsating DC signal.

Ripple factor is defined as the ratio of ripple voltage to the pure DC voltage

The ripple factor is given by

$$\gamma = \sqrt{\left(\frac{V_{\text{rms}}}{V_{\text{DC}}}\right)^2 - 1}$$

Finally, we get

$$\gamma = 0.48$$

RECTIFIER EFFICIENCY

Rectifier efficiency indicates how efficiently the rectifier converts AC into DC. A high percentage of rectifier efficiency indicates a good rectifier while a low percentage of rectifier efficiency indicates an inefficient rectifier.

Rectifier efficiency is defined as the ratio of DC output power to the AC input power.

It can be mathematically written as

$$\eta = \text{output } P_{\text{DC}} / \text{input } P_{\text{AC}}$$

The rectifier efficiency of a full wave rectifier is 81.2%.

The rectifier efficiency of a full wave rectifier is twice that of the half wave rectifier. So the full wave rectifier is more efficient than a half wave rectifier

PEAK INVERSE VOLTAGE (PIV)

Peak inverse voltage or peak reverse voltage is the maximum voltage a diode can withstand in the reverse bias condition. If the applied voltage is greater than the peak inverse voltage, the diode will be permanently destroyed.

The peak inverse voltage (PIV) = $2V_{\text{smax}}$

DC OUTPUT CURRENT

At the output load resistor R_L , both the diode D_1 and diode D_2 currents flow in the same direction. So the output current is the sum of D_1 and D_2 currents.

The current produced by D_1 is I_{\max} / π and the current produced by D_2 is I_{\max} / π .

So the output current $I_{DC} = 2I_{\max} / \pi$

Where,
 I_{\max} = maximum DC load current

DC OUTPUT VOLTAGE

The DC output voltage appeared at the load resistor R_L is given as

$V_{DC} = 2V_{\max} / \pi$
Where,
 V_{\max} = maximum secondary voltage

ROOT MEAN SQUARE (RMS) VALUE OF LOAD CURRENT I_{RMS}

The root mean square (RMS) value of load current in a full wave rectifier is

$$I_{RMS} = \frac{I_m}{\sqrt{2}}$$

Root mean square (RMS) value of the output load voltage V_{RMS}

The root mean square (RMS) value of output load voltage in a full wave rectifier is

$$V_{RMS} = I_{RMS} R_L = \frac{I_m}{\sqrt{2}} R_L$$

FORM FACTOR

Form factor is the ratio of RMS value of current to the DC output current

It can be mathematically written as

$$F.F = \text{RMS value of current} / \text{DC output current}$$

The form factor of a full wave rectifier is

BRIDGE RECTIFIER

Another type of rectifier circuit that produces the similar DC output waveform as a full wave rectifier circuit is a full wave bridge rectifier circuit. As the name indicates, the full wave bridge rectifier requires four power diodes arranged as a bridge circuit as shown in figure to give full wave rectification without any need of a centre tapped transformer. It has to be observed for each and every half cycle, the diodes in opposite pairs will conduct, while the amount of current flowing across the load remains in the same polarity for both the positive and negative half cycles. Diodes D1 and D2 conduct for the positive half cycle of the input (AC supply) while D3 and D4 conduct for the negative half cycle.

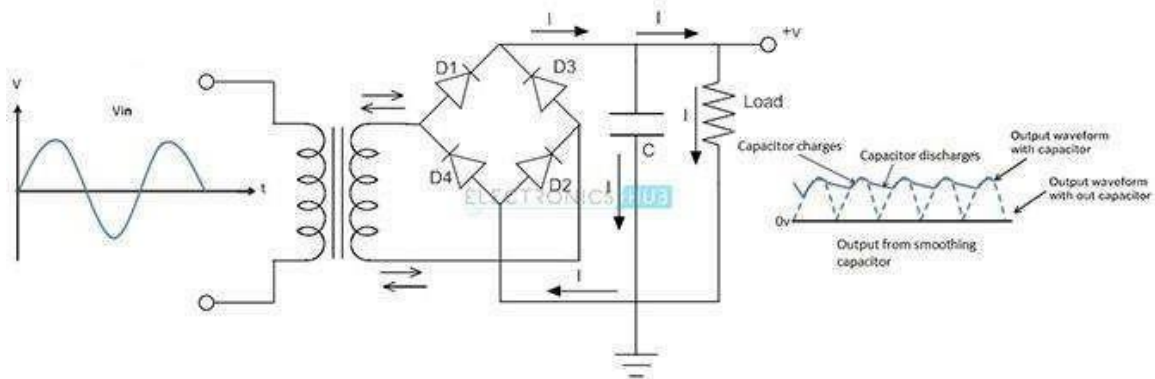

To eliminate the ripples present in the DC output waveform, the smoothing capacitor having a typical value of 100 micro Farads or more should be used. In choosing the smoothing capacitor, the parameters that should be kept in mind are the working voltage and capacitance value. The value of working voltage should be greater than the output value of rectifier when no load is connected.

VOLTAGE DOUBLER

The electronic circuit that generates an output voltage equal to double the input voltage is called a **voltage doubler**. It is also known as a voltage multiplier, as it multiplies the input voltage with a multiplication factor equal to 2.

It is important to note that we can increase the level of voltage by using a step-up transformer, however, the transformers are heavier and costlier devices. Therefore, for small electronic circuits and low-cost applications, a voltage-doubling circuit is used to increase the voltage level. A voltage doubler can increase the input voltage by a multiplication factor of 2 by using small electronic components like diodes and capacitors.

TYPES OF VOLTAGE DOUBLER

Voltage doublers are classified into the following two main types namely,

- Half Wave voltage doubler
- Full Wave voltage doubler

Let us discuss each type of doubler circuit in detail along with the construction and circuit diagram.

HALF WAVE VOLTAGE DOUBLER

A half-wave voltage doubler circuit diagram is shown in the following figure.

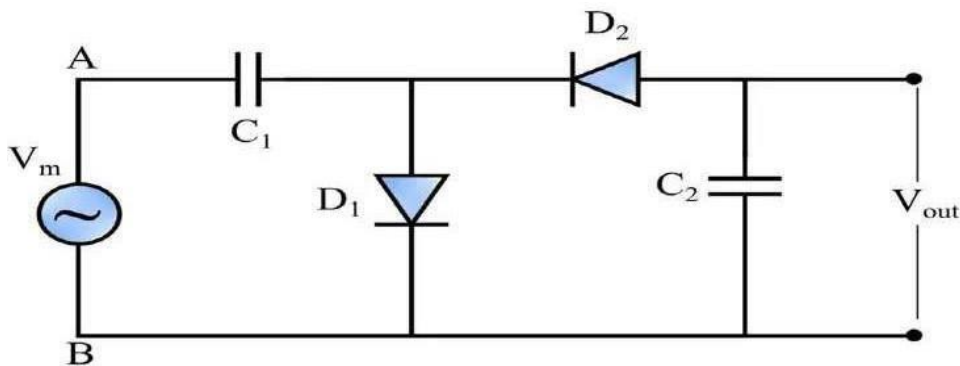

It consists of two pn-junction diodes and two capacitors that operate together to produce a double voltage of the input voltage.

During the positive half-cycle of the input ac voltage, terminal A is at positive potential. In this period, the diode D_1 conducts and charges the capacitor C_1 to the maximum value of the input ac voltage V_m .

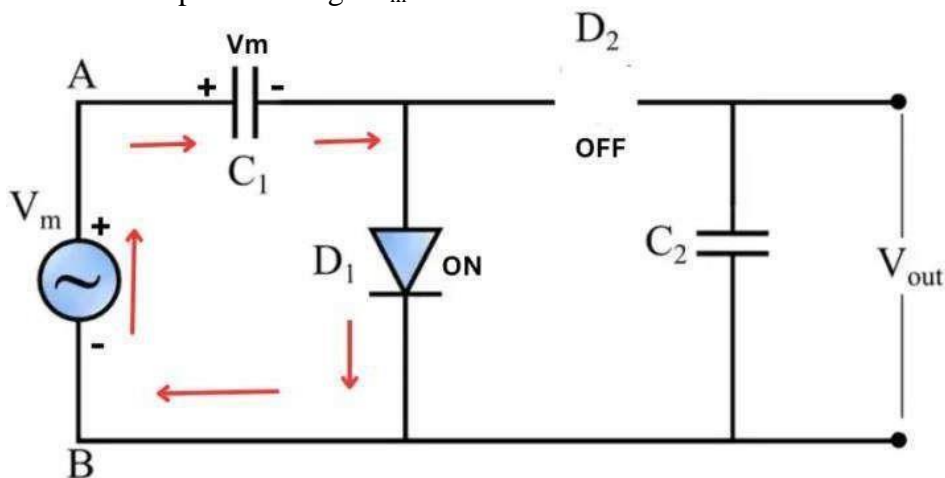

The capacitor C_1 cannot release its energy due to the unavailability of a path because diode D_2 is in reverse bias and hence remains in the fully charged state.

Next, during the negative half cycle, terminal B is positive and diode D_2 starts conducting and diode D_1 turned off due to the reverse bias state. Thus, the diode D_1 being non-conducting stops the discharging of the capacitor C_1 , meanwhile, the diode D_2 conducts and charges the capacitor C_2 to a peak voltage $2V_m$.

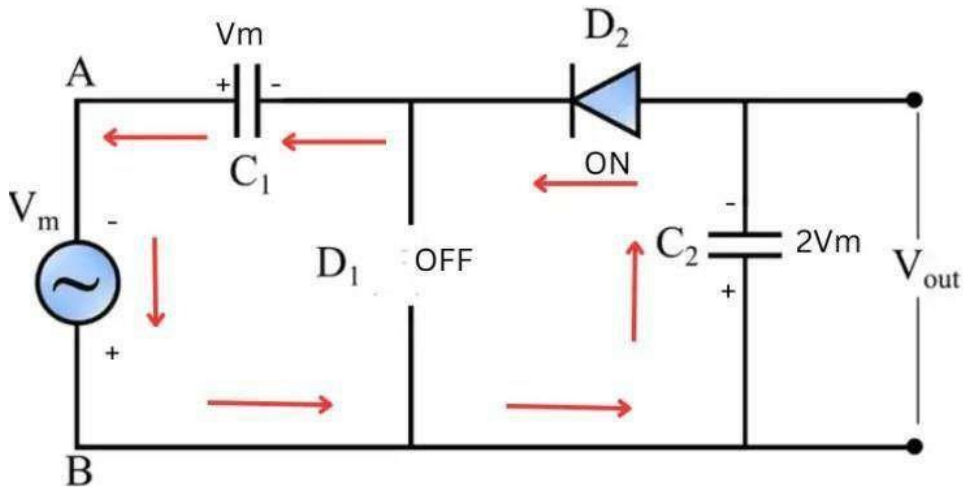

If V_1 and V_2 are the voltages across the capacitors C_1 and C_2 respectively, by applying KVL in the loop of the voltage doubling circuit, we get,

$$-V_m - V_1 + V_2 = 0$$

$$\therefore V_1 = V_m$$

$$\therefore V_2 = V_m + V_m = 2V_m = V_{out}$$

In the case of a half-wave voltage doubler circuit, the output voltage increases slowly. Another factor is that simply one-half cycle charges the capacitor C_2 . The output voltage has a ripple frequency equivalent to the supply frequency because a one-half cycle charges the capacitor C_2 .

The input and output waveform of the half-wave doubler circuit is shown in the below picture.

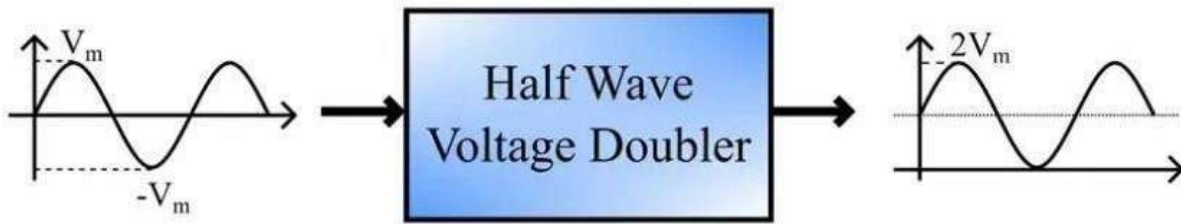

(2). FULL WAVE VOLTAGE DOUBLER

A full wave doubler circuit diagram is shown in the following figure.

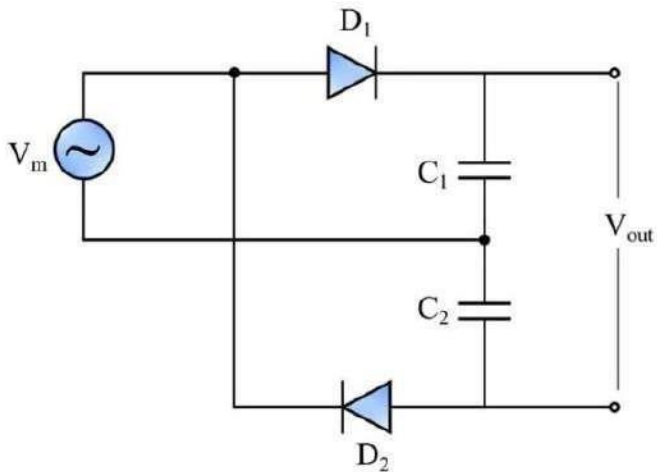

Like the half-wave doubler, it also consists of two diodes and two capacitors, but the circuit's configuration differs.

During the positive half cycle of input ac voltage, the diode D_1 conducts and charges the capacitor C_1 to the maximum voltage V_m .

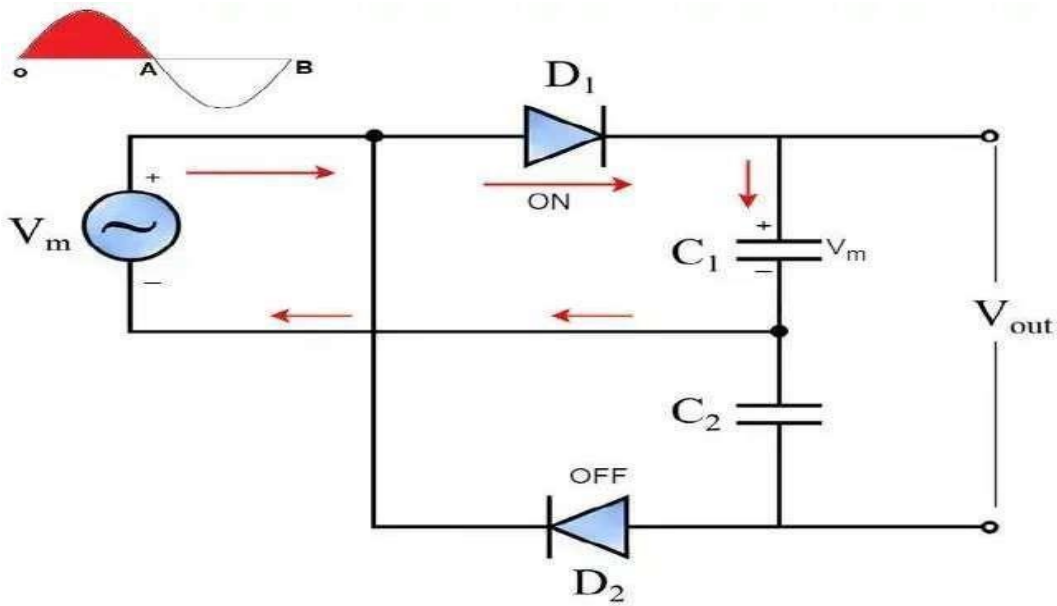

Capacitor Charging Current During Positive Half Cycle (OA)

During the negative half cycle of the input ac voltage, the diode D_2 will conduct and charges the capacitor C_2 to the maximum voltage V_m . During this period, the diode D_1 will be in non-conducting mode.

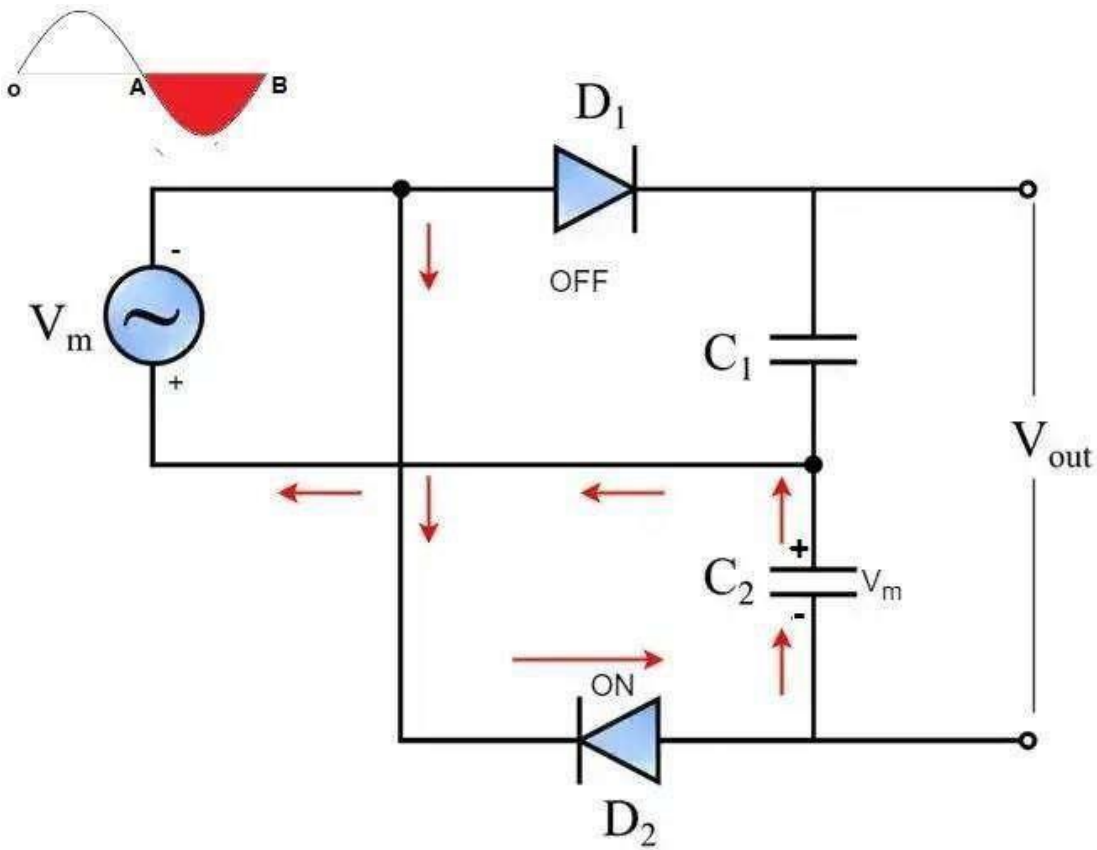

Capacitor Charging Current during negative Half Cycle(AB)

Since the two capacitors are connected in series, hence the output voltage will be equal to the sum of the voltages across the two capacitors.

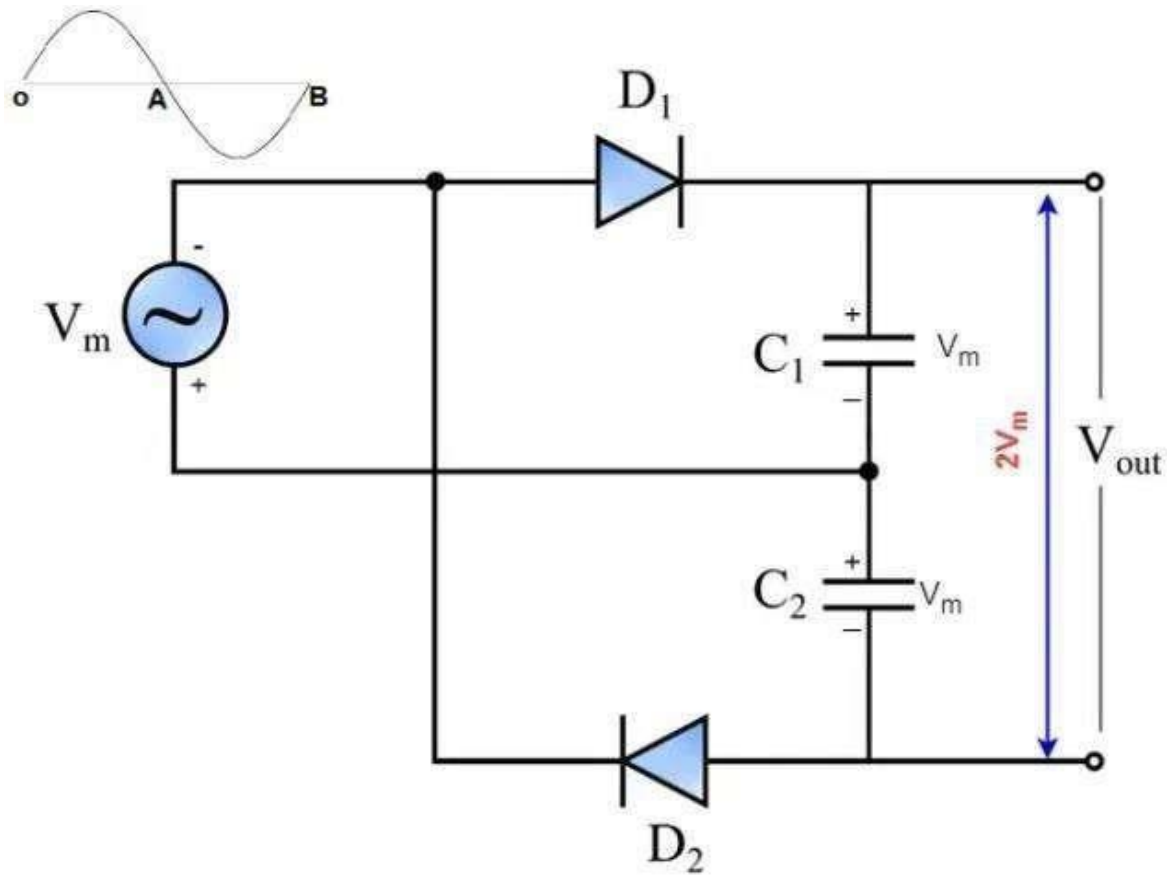

Output voltage across Capacitors for one Cycle(OB)

Therefore,

$$V_{out} = V_1 + V_2 = 2V_m$$

The input and output waveform of the full wave doubler circuit is shown in the below figure.

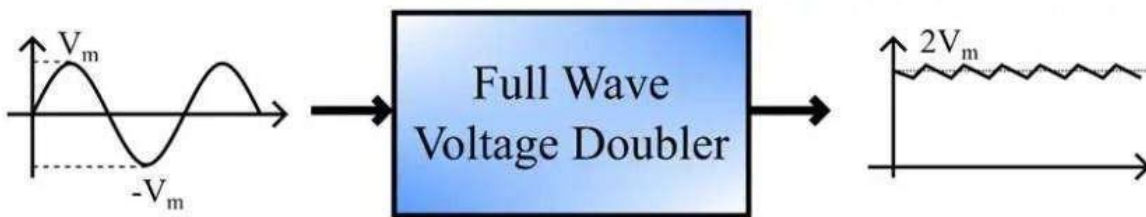

ADVANTAGES

A voltage doubler circuit has several advantages over a step-up transformer. Some key advantages are listed here:

- Light in weight and can replace heavy transformers
- Less expensive.
- More energy efficient due to the use of solid-state diodes.
- Easily scaled to higher order voltage multipliers simply by cascading more stages of voltage multiplication

DISADVANTAGES

Apart from the advantages, voltage doublers also have some disadvantages. Some major disadvantages of voltage doublers are listed below:

- It Contains unwanted fluctuation, known as ripples
- Poor voltage regulation.
- Its output voltage depends upon the charge stored in the capacitors.
- It requires additional filter circuits to smooth the output voltage.

APPLICATIONS OF VOLTAGE DOUBLER

The following are some important applications.

- Used in cathode ray tube televisions.
- Used in photocopier machines.
- They are also used in radar machines and X-rays machine.
- Also used in ion pumps and traveling wave tubes.

CAPACITOR FILTER FOR LOW POWER RECTIFIERS:

HALF WAVE RECTIFIER WITH CAPACITOR FILTER

The main function of half wave rectifier is to change the AC (Alternating Current) into DC (Direct Current). However, the acquired output DC is not pure and it is an exciting DC. This DC is not constant and varies with time. Whenever this changing DC is given to any type of electronic device, then it may not function correctly, and that may get damaged. Due to this reason, it will not be applicable in most of the applications.

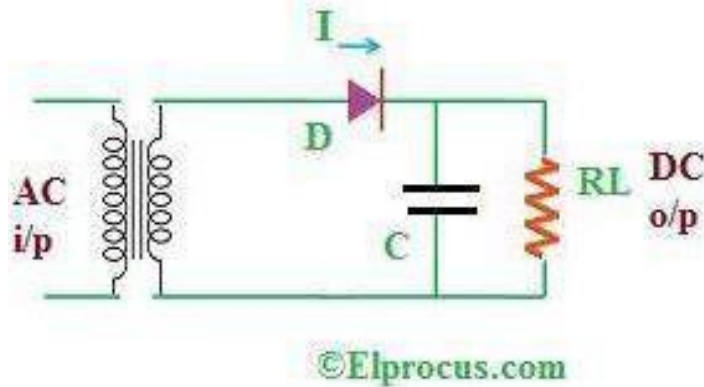

HALFWAVE RECTIFIER WITH CAPACITOR FILTER

Thus, we require a DC that does not change with time. To overcome this problem and to get a smooth DC, there will be solutions namely filter. The energetic DC mainly includes both AC & DC components. So here filter is used to remove or reduce the AC components at the output. The filter can be built with components like resistors, capacitors, and inductors. The circuit diagram of half wave rectifier using a capacitor filter is shown above. This circuit is built with a resistor and capacitor. Here, the connection of the capacitor 'C' is in shunt with the 'RL' load resistor.

Whenever AC voltage is applied to the circuit throughout the positive half cycle, then the diode lets the flow of current through it. We know that the capacitor gives high-resistive lane to DC components as well as low-resistive lane to AC components. The flow of current always chooses to supply through a low resistance lane. So when the flow of current gets the filter, the ac components experience a low-resistance and dc components experience a high- resistance from the capacitor. The DC components flow through the load resistor (low resistance path).

Throughout the conduction time, the capacitor gets charged to the highest value of the voltage supply. As the voltage among the two plates of the capacitor is equivalent to the voltage supply, then it is said to be completely charged. When it gets charged then it holds the supply until the supply of i/p AC toward the rectifier achieves the negative half cycle.

Once the rectifier reaches to negative half cycle, the diode acquires reverse biased & stops letting the flow of current through it. Throughout this, the supply voltage is low then the voltage of a capacitor. Thus the capacitor releases all the stored current through the RL. This stops the o/p load voltage from falling to nil.

The charging and discharging of the capacitor mainly depends on when the input voltage supply is less or greater than the capacitor voltage. Once the rectifier reaches the positive half cycle, then the diode acquires forward biased & allows the flow of current to make the capacitor charge again. The capacitor filter through a huge discharge will generate an extremely smooth DC voltage. Therefore, a smooth DC voltage can be attained with this filter.

FULL WAVE RECTIFIER WITH CAPACITOR FILTER

The main function of full wave rectifier is to convert an AC into DC. As the name implies, this rectifier rectifies both the half cycles of the i/p AC signal, but the DC signal acquired at the o/p still have some waves. To decrease these waves at the o/p this filter is used. In the full wave rectifier circuit using a capacitor filter, the capacitor C is located across the RL load resistor. The working of this rectifier is almost the same as a half wave rectifier. The only dissimilarity is half wave rectifier has just one-half cycles (positive or negative) whereas in full wave rectifier has two cycles (positive and negative).

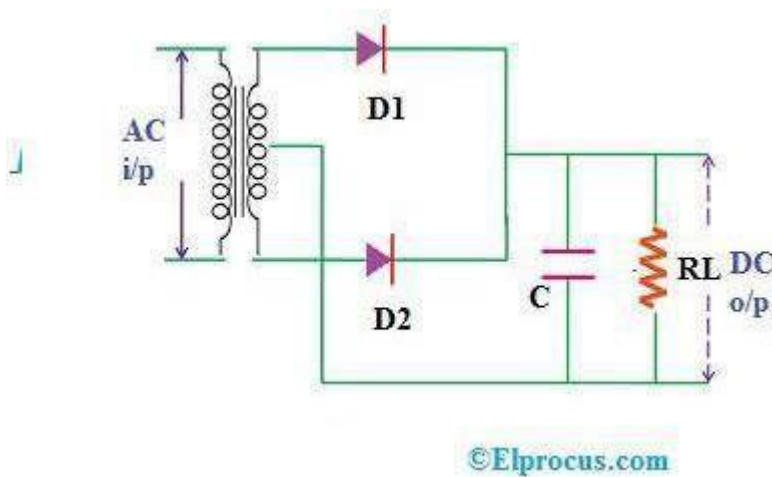

FULL-WAVE RECTIFIER WITH CAPACITOR FILTER

Once the i/p AC voltage is applied throughout the positive half cycle, then the D1 diode gets forward biased and permits flow of current while the D2 diode gets reverse biased & blocks the flow of current.

Throughout the above half cycle, the current in the D1 diode gets the filter and energizes the capacitor. But, the capacitor charging will occur just when the voltage which is applied is superior to the capacitor voltage. Firstly, the capacitor will not charge, as no voltage will stay among the capacitor plates. So when the voltage is switched on, then the capacitor will get charged immediately.

Throughout this transmission time, the capacitor gets charged to the highest value of the i/p voltage supply. The capacitor includes a highest charge at the quarter waveform in the positive half cycle. At this end, the voltage supply is equivalent to the voltage of the capacitor. Once the AC voltage begins falling & turns into less than the voltage of the capacitor, after that the capacitor begins discharging gradually.

As the i/p AC voltage supply gets the negative half-cycle, then the D1 diode gets reverse biased but the D2 diode is forward biased. Throughout the negative half cycle, the flow of current in the second diode gets the filter to charge the capacitor. But, the capacitor charging occurs simply while the applied AC voltage is superior to the voltage of the capacitor.

The capacitor in the circuit is not charged fully, so the charging of this does not occur instantly. Once the voltage supply becomes superior to the voltage of the capacitor, the capacitor gets charging. In both the half cycles, the flow of current will be in the similar direction across the RL load resistor. Thus we acquire either whole positive half cycle otherwise negative half cycle. In this case, we can get the total positive half cycle.

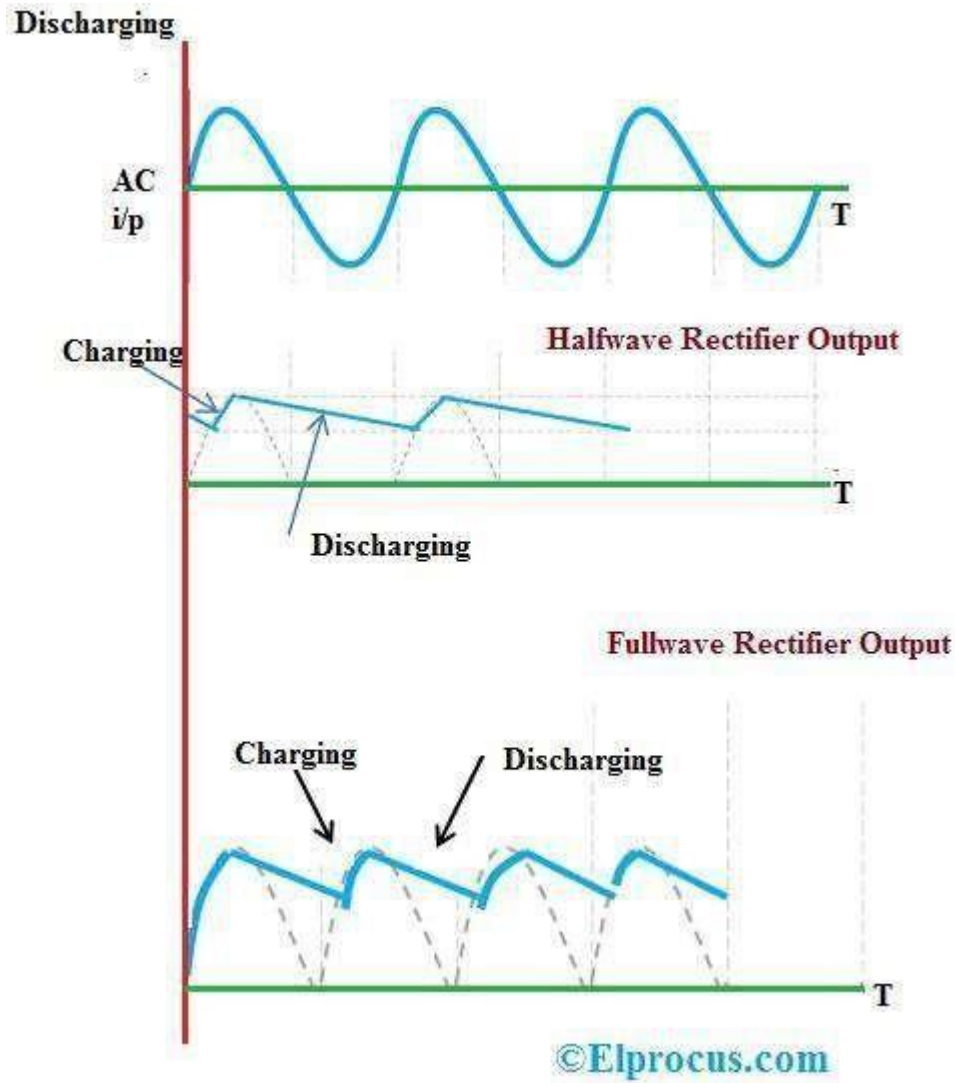

Halfwave & Full-wave Rectifier with Capacitor Filter Outputs

LC FILTER:

LC filter, or L-C filter, is a passive electronic circuit consisting of an inductor (L) and a capacitor (C) connected in series or parallel. LC filters are commonly used in power electronic circuits, including power diode rectifiers, to reduce or eliminate unwanted harmonics and ripple in the output voltage. In power diode rectifiers, LC filters can help smoothen the rectified DC voltage and reduce electromagnetic interference (EMI). Here's how an LC filter works in the context of a power diode rectifier:

COMPONENTS:

1. **Power Diode Rectifier:** The power diode rectifier is used to convert an AC voltage source into DC voltage. It typically consists of diodes arranged in a bridge configuration, as explained in a previous response.
2. **LC Filter:** The LC filter is connected to the output of the rectifier. It consists of an inductor (L) and a capacitor (C) and is connected in series or parallel to filter the rectified DC voltage.

OPERATION:

1. **Rectified Voltage:** After the AC voltage is rectified by the diodes in the rectifier, the output voltage contains a significant amount of ripple. This ripple is due to the fact that diodes only allow current flow during specific portions of the AC waveform.
2. **Inductor (L):** The inductor in the LC filter is placed in series with the rectified voltage. It smoothens the voltage waveform by resisting changes in current. The inductor stores energy in its magnetic field when current is increasing and releases energy when current is decreasing.
3. **Capacitor (C):** The capacitor in the LC filter is connected in parallel with the load (or sometimes in parallel with the inductor). It acts as a storage element for electrical charge and helps reduce voltage ripple by charging and discharging as the load draws current.
4. **Filtering Action:** The LC filter combination effectively forms a low-pass filter. The inductor attenuates high-frequency components in the voltage ripple, while the capacitor shunts these components to ground, reducing the ripple amplitude.

Benefits of Using an LC Filter in a Power Diode Rectifier:

1. **Ripple Reduction:** The LC filter significantly reduces the amplitude of the ripple in the output voltage, resulting in a smoother and more stable DC voltage. This is beneficial for many applications that require a relatively constant DC voltage.
2. **Harmonic Reduction:** In addition to ripple reduction, the LC filter also helps reduce harmonic components in the output voltage, improving the overall quality of the output waveform.
3. **EMI Suppression:** The LC filter helps suppress electromagnetic interference (EMI) by reducing voltage and current transients in the circuit. This can be essential in applications where EMI compliance is required.

It's important to select the appropriate values for the inductor and capacitor in the LC filter to match the specific requirements of the application. The design of LC filters involves considerations of the load, desired output voltage, and the frequency and magnitude of the unwanted harmonics in the system.

CONCERN FOR POWER QUALITY:

Power quality is a significant concern in various applications that use uncontrolled rectifiers, especially in systems where stable and clean DC voltage is essential. Uncontrolled rectifiers, such as bridge rectifiers with power diodes, are known to introduce certain power quality issues:

1. **Harmonic Distortion:** Uncontrolled rectifiers are prone to producing a significant amount of harmonic distortion in the output voltage. The rectified output is not a pure DC voltage but rather a pulsating waveform with a high content of odd-order harmonics. This harmonic distortion can cause several problems, including increased losses in connected equipment and electrical systems, potential overheating of transformers and conductors, and electromagnetic interference.
2. **Voltage Ripple:** Due to the switching characteristics of power diodes in uncontrolled rectifiers, the output voltage exhibits ripple. The voltage ripple can affect the performance of sensitive electronic equipment, causing misoperation or damage. In applications where a stable and constant DC voltage is required, the ripple can be problematic.
3. **Voltage Sag and Swell:** Uncontrolled rectifiers do not provide voltage regulation, so the output voltage may vary with changes in the input AC voltage. This can lead to voltage sags (temporary drops) or voltage swells (temporary increases), which can adversely affect the operation of connected equipment, particularly in sensitive applications.
4. **Electromagnetic Interference (EMI):** The high-frequency switching inherent to uncontrolled rectifiers can generate electromagnetic interference. This can disrupt the operation of nearby electronic devices and lead to EMI compliance issues in certain applications.

To address these power quality concerns in systems using uncontrolled rectifiers, various mitigation strategies can be employed:

1. **Harmonic Filters:** Passive harmonic filters (such as L-C filters) or active filters can be installed to reduce the harmonic content in the output of the rectifier. These filters help mitigate the impact of harmonics on the power distribution system and sensitive loads.
2. **Voltage Regulation:** Additional voltage regulation circuits, such as voltage stabilizers or uninterruptible power supplies (UPS), can be used to provide a stable output voltage in the presence of variations in the input AC voltage.
3. **EMI Filters:** EMI filters can be employed to suppress electromagnetic interference generated by the uncontrolled rectifier and associated power electronics.
4. **Load Considerations:** The design of the load should consider the characteristics of the uncontrolled rectifier, and additional filtering or conditioning may be necessary to ensure the proper operation of sensitive equipment.
5. **Isolation Transformers:** The use of isolation transformers can help provide electrical isolation and reduce some voltage quality issues.

In summary, while uncontrolled rectifiers are cost-effective and widely used, they can introduce power quality challenges, particularly in applications that require a high-quality and stable power supply. Careful system design and the use of additional components can help mitigate these issues and improve overall power quality.

THREE PHASE RECTIFICATION

3-phase rectification is the process of converting a balanced 3-phase power supply into a fixed DC supply using solid state diodes or thyristors

We saw that the process of converting an AC input supply into a fixed DC supply is called *Rectification* with the most popular circuits used to perform this rectification process is one that is based on solid-state semiconductor diodes.

In fact, rectification of alternating voltages is one of the most popular applications of diodes, as diodes are inexpensive, small and robust allowing us to create numerous types of rectifier circuits using either individually connected diodes or with just a single integrated bridge rectifier module.

Single phase supplies such as those in houses and offices are generally 120 Vrms or 240 Vrms phase-to-neutral, also called line-to-neutral (L-N), and nominally of a fixed voltage and frequency producing an alternating voltage or current in the form of a sinusoidal waveform being given the abbreviation of “AC”.

Three-phase rectification, also known as poly-phase rectification circuits are similar to the previous single-phase rectifiers, the difference this time is that we are using three, single-phase supplies connected together that have been produced by one single three-phase generator.

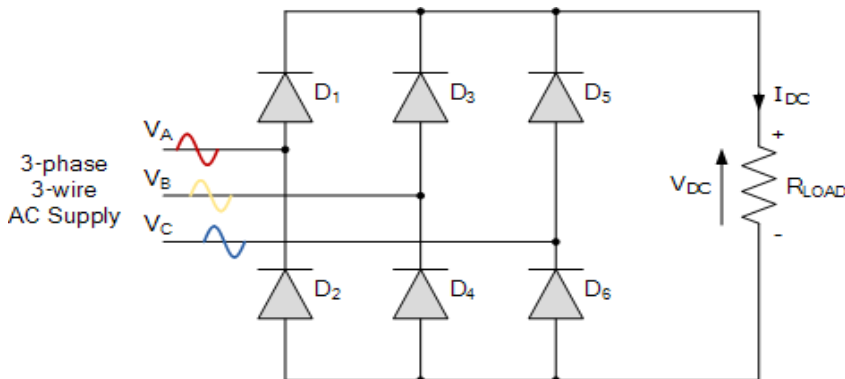

The advantage here is that 3-phase rectification circuits can be used to power many industrial applications such as motor control or battery charging which require higher power requirements than a single-phase rectifier circuit is able to supply.

3-phase supplies take this idea one step further by combining together three AC voltages of identical frequency and amplitude with each AC voltage being called a “phase”. These three phases are 120 electrical degrees out-of-phase from each other producing a phase sequence, or phase rotation of: $360^\circ \div 3 = 120^\circ$ as shown.

THREE-PHASE WAVEFORM

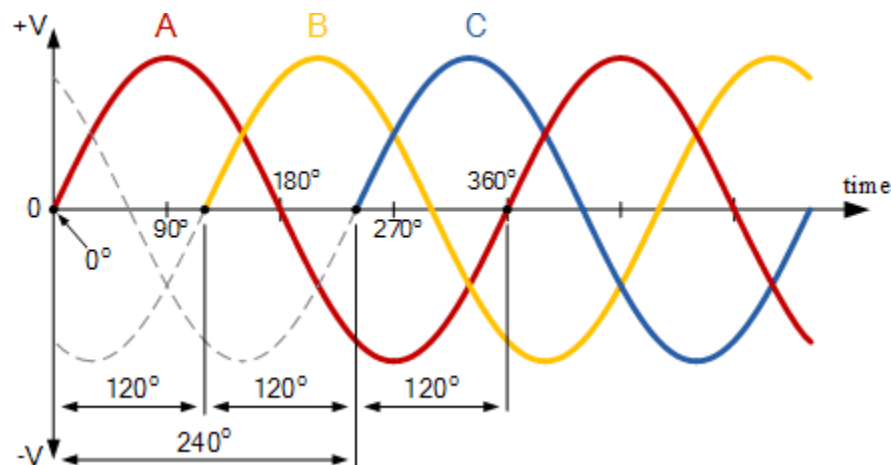

The advantage here is that a three-phase alternating current (AC) supply can be used to provide electrical power directly to balanced loads and rectifiers. Since a 3-phase supply has a fixed voltage and frequency it can be used by a rectification circuit to produce a fixed voltage DC power which can then be filtered resulting in an output DC voltage with less ripple compared to a single-phase rectifying circuit.

THREE-PHASE RECTIFICATION

Having seen that a 3-phase supply is just simply three single-phases combined together, we can use this multi-phase property to create 3-phase rectifier circuits.

As with single-phase rectification, three-phase rectification uses diodes, thyristors, transistors, or converters to create half-wave, full-wave, uncontrolled and fully-controlled rectifier circuits transforming a given three-phase supply into a constant DC output level. In most applications a three-phase rectifier is supplied directly from the mains utility power grid or from a three-phase transformer if different DC output level is required by the connected load.

As with the previous single-phase rectifier, the most basic three-phase rectifier circuit is that of an uncontrolled half-wave rectifier circuit which uses three semiconductor diodes, one diode per phase as shown.

HALF-WAVE THREE-PHASE RECTIFICATION

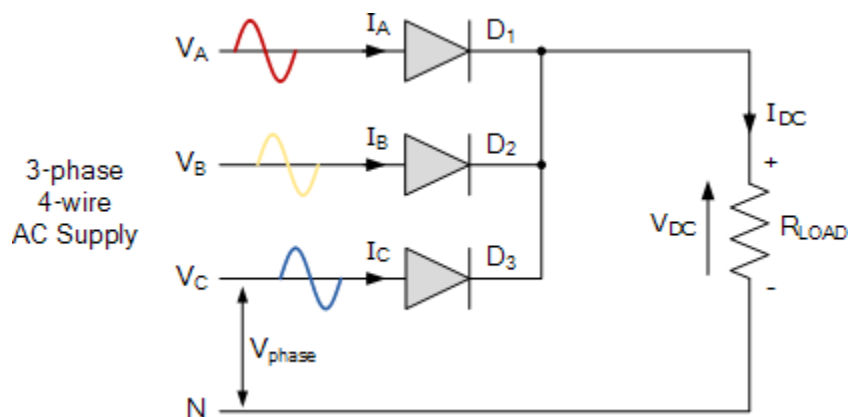

So how does this three-phase half-wave rectifier circuit work. The anode of each diode is connected to one phase of the voltage supply with the cathodes of all three diodes connected together to the same positive point, effectively creating a diode-“OR” type arrangement. This common point becomes the positive (+) terminal for the load while the negative (-) terminal of the load is connected to the neutral (N) of the supply.

Assuming a phase rotation of Red-Yellow-Blue ($V_A - V_B - V_C$) and the red phase (V_A) starts at 0° . The first diode to conduct will be diode 1 (D_1) as it will have a more positive voltage at its anode than diodes D_2 or D_3 . Thus diode D_1 conducts for the positive half-cycle of V_A while D_2 and D_3 are in their reverse-biased state. The neutral wire provides a return path for the load current back to the supply.

120 electrical degrees later, diode 2 (D_2) starts to conduct for the positive half-cycle of V_B (yellow phase). Now its anode becomes more positive than diodes D_1 and D_3 which are both “OFF” because they are reversed-biased. Similarly, 120° later V_C (blue phase) starts to increase turning “ON” diode 3 (D_3) as its anode becomes more positive, thus turning “OFF” diodes D_1 and D_2 .

Then we can see that for three-phase rectification, whichever diode has a more positive voltage at its anode compared to the other two diodes it will automatically start to conduct, thereby giving a conduction pattern of: $D_1 D_2 D_3$ as shown.

HALF-WAVE THREE-PHASE RECTIFIER CONDUCTION WAVEFORM

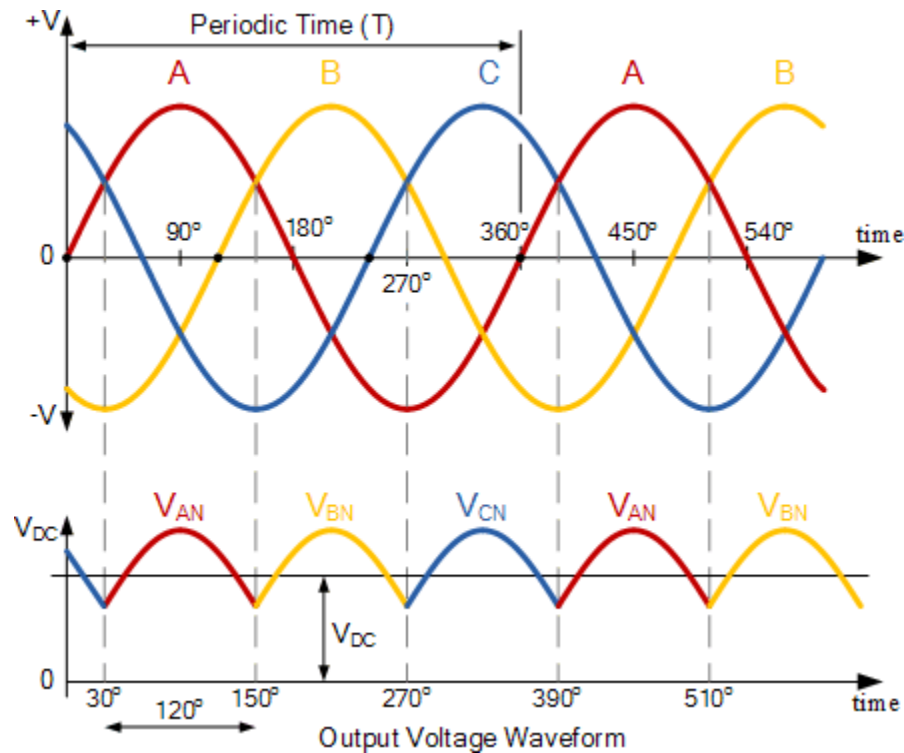

From the above waveforms for a resistive load, we can see that for a half-wave rectifier each diode passes current for one third of each cycle, with the output waveform being three times the input frequency of the AC supply. Therefore there are three voltage peaks in a given cycle, so by increasing the number of phases from a single-phase to a three-phase supply, the rectification of the supply is improved, that is the output DC voltage is smoother.

For a three-phase half-wave rectifier, the supply voltages V_A , V_B and V_C are balanced but with a phase difference of 120° giving:

$$V_A = V_P \cdot \sin(\omega t - 0^\circ)$$

$$V_B = V_P \cdot \sin(\omega t - 120^\circ)$$

$$V_C = V_P \cdot \sin(\omega t - 240^\circ)$$

Thus the average DC value of the output voltage waveform from a 3-phase half-wave rectifier is given as:

$$V_{DC} = \frac{3\sqrt{3}}{2\pi} V_P = 0.827 \cdot V_{PEAK}$$

As the voltage supplies peak voltage, V_P is equal to $V_{RMS} \cdot 1.414$, it therefore follows that V_{RMS} is equal to $V_P / 1.414$, or $0.707 \cdot V_P$ as $1/1.414 = 0.707$. Then the average DC output voltage of the rectifier can be expressed in terms of its root-mean-squared (RMS) phase voltage as follows:

$$V_P = 1.414 \times V_{RMS} \quad \therefore V_{RMS} = \frac{V_P}{1.414}$$

$$V_{DC} = \frac{3\sqrt{3}}{2\pi} \times V_P = 0.827 \times V_P$$

Convert to V_{RMS}

$$V_{DC} = 0.827 \times 1.414 \times V_{RMS}$$

$$\therefore V_{DC} = \frac{0.827}{0.707} V_{RMS} = 1.17 \times V_{RMS}$$

3-PHASE RECTIFICATION

A half-wave 3-phase rectifier is constructed using three individual diodes and a 120VAC 3-phase star connected transformer. If it is required to power a connected load with an impedance of 50Ω , Calculate, a) the average DC voltage output to the load. b) the load current, c) the average current per diode. Assume ideal diodes.

A). THE AVERAGE DC LOAD VOLTAGE:

$$V_{DC} = 1.17 \times V_{rms} = 1.17 \times 120 = 140.4 \text{ volts}$$

Note that if we were given the peak voltage (V_p) value, then:

$$V_{DC} \text{ would equal } 0.827 \times V_p \text{ or } 0.827 \times 169.68 = 140.4V.$$

B). THE DC LOAD CURRENT:

$$I_L = V_{DC}/R_L = 140.4/50 = 2.81 \text{ amperes}$$

C). THE AVERAGE CURRENT PER DIODE:

$$I_D = I_L/3 = 2.81/3 = 0.94 \text{ amperes}$$

One of the disadvantages of half-wave 3-phase rectification is that it requires a 4-wire supply, that is three phases plus a neutral (N) connection. Also the average DC output voltage is low at a value represented by $0.827 \times V_P$ as we have seen.

This is because the output ripple content is three times the input frequency. But we can improve on these disadvantages by adding three more diodes to the basic rectifier circuit creating a three-phase full-wave uncontrolled bridge rectifier.

FULL-WAVE THREE-PHASE RECTIFICATION

The full-wave three-phase uncontrolled bridge rectifier circuit uses six diodes, two per phase in a similar fashion to the single-phase bridge rectifier. A 3-phase full-wave rectifier is obtained by using two half-wave rectifier circuits. The advantage here is that the circuit produces a lower ripple output than the previous half-wave 3-phase rectifier as it has a frequency of six times the input AC waveform.

Also, the full-wave rectifier can be fed from a balanced 3-phase 3-wire delta connected supply as no fourth neutral (N) wire is required. Consider the full-wave 3-phase rectifier circuit below.

FULL-WAVE THREE-PHASE RECTIFICATION

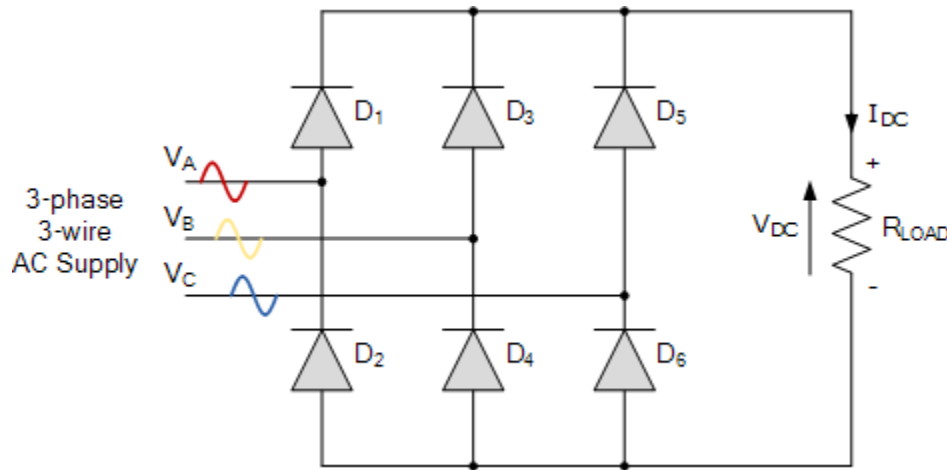

As before, assuming a phase rotation of Red-Yellow-Blue ($V_A - V_B - V_C$) and the red phase (V_A) starts at 0° . Each phase connects between a pair of diodes as shown. One diode of the conducting pair powers the positive (+) side of load, while the other diode powers the negative (-) side of load.

Diodes D_1 D_3 D_2 and D_4 form a bridge rectifier network between phases A and B, similarly diodes D_3 D_5 D_4 and D_6 between phases B and C and D_5 D_1 D_6 and D_2 between phases C and A.

Diodes D_1 D_3 and D_5 feed the positive rail. The diode which has a more positive voltage at its anode terminal conducts. Likewise, diodes D_2 D_4 and D_6 feed the negative rail and whichever diode has a more negative voltage at its cathode terminal conducts.

Then we can see that for three-phase uncontrolled rectification the diodes conduct in matching pairs with each conduction path passing through two diodes in series. Thus a total of six rectifier diodes are required with commutation of the circuit taking place every 60° , or six times per cycle.

If we start the pattern of conduction at 30°, this gives us a conduction pattern for the load current of: D₁₋₄ D₁₋₆ D₃₋₆ D₃₋₂ D₅₋₂ D₅₋₄ and return again to D₁₋₄ and D₁₋₆ for the next phase sequence as shown.

FULL-WAVE THREE-PHASE RECTIFIER CONDUCTION WAVEFORM

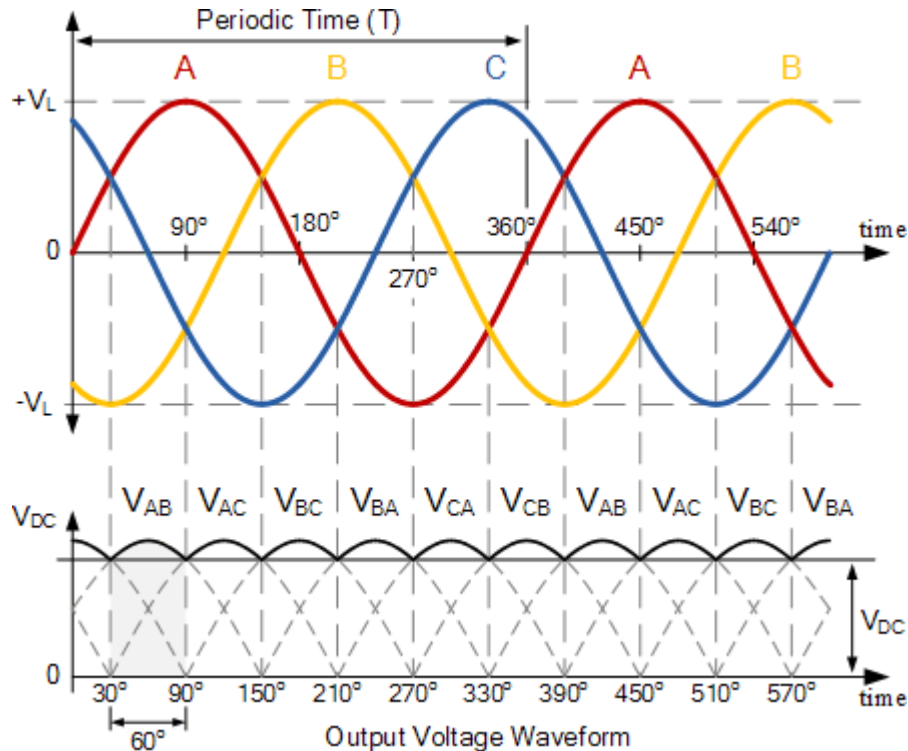

In 3-phase power rectifiers, conduction always occurs in the most positive diode and the corresponding most negative diode. Thus as the three phases rotate across the rectifier terminals, conduction is passed from diode to diode.

Then each diode conducts for 120° (one-third) in each supply cycle but as it takes two diodes to conduct in pairs, each pair of diodes will conduct for only 60° (one-sixth) of a cycle at any one time as shown above.

Therefore we can correctly say that for a 3-phase rectifier being fed by “3” transformer secondaries, each phase will be separated by 360°/3 thus requiring 2*3 diodes.

Note also that unlike the previous half-wave rectifier, there is no common connection between the rectifiers input and output terminals. Therefore it can be fed by a star connected or a delta connected transformer supply.

So the average DC value of the output voltage waveform from a 3-phase full-wave rectifier is given as:

$$V_{DC} = \frac{3\sqrt{3}}{\pi} V_S = 1.65 * V_S$$

Where: V_S is equal to $(V_{L(PEAK)} \div \sqrt{3})$ and where $V_{L(PEAK)}$ is the maximum line-to-line voltage ($V_L * 1.414$).

3-PHASE RECTIFICATION

A 3-phase full-wave bridge rectifier is required to feed a 150Ω resistive load from a 3-phase 127 volt, 60Hz delta connected supply. Ignoring the voltage drops across the diodes, calculate: 1. the DC output voltage of the rectifier and 2. the load current.

1. THE DC OUTPUT VOLTAGE:

The RMS (Root Mean Squared) line voltage is 127 volts. Therefore the line-to-line peak voltage ($V_{L-L(PEAK)}$) will be:

$$V_{L(PEAK)} = V_{L(RMS)} \times \sqrt{2} = 127 \times 1.414 = 179.6V$$

As the supply is 3-phase, the phase to neutral voltage (V_{P-N}) of any phase will be:

$$V_S = V_{L(PEAK)} \div \sqrt{3} = 179.6 \div 1.732 = 103.7V$$

Note that this is basically the same as saying:

$$V_S = \frac{V_{L(RMS)} \times \sqrt{2}}{\sqrt{3}} = 103.7V$$

Thus the average DC output voltage from the 3-phase full-wave rectifier is given as:

$$V_{DC} = \left[\frac{3\sqrt{3}}{\pi} \right] V_S = 1.654 \times V_S$$

$$\therefore V_{DC} = 1.654 \times 103.7 = 171.5V$$

Again, we can reduce the maths a bit by correctly saying that for a given line-to-line RMS voltage value, in our example 127 volts, the average DC output voltage is:

$$V_{DC} = \frac{3\sqrt{2}}{\pi} V_{L(RMS)} = 1.35 \times 127 = 171.5V$$

2. THE RECTIFIERS LOAD CURRENT.

The output from the rectifier is feeding a 150Ω resistive load. Then using Ohms law the load current will be:

$$I_{LOAD} = V_S \div R_L = 171.5 \div 150 = 1.14 \text{ Amps}$$

Uncontrolled 3-phase rectification uses diodes to provide an average output voltage of a fixed value relative to the value of the input AC voltages. But to vary the output voltage of the rectifier we need to replace the uncontrolled diodes, either some or all of them, with thyristors to create what are called half-controlled or fully-controlled bridge rectifiers.

Thyristors are three terminal semiconductor devices and when a suitable trigger pulse is applied to the thyristors gate terminal when its Anode-to-Cathode terminal voltage is positive, the device will conduct and pass a load current.

So by delaying the timing of the trigger pulse, (firing angle) we can delay the instant in time at which the thyristor would naturally switch “ON” if it were a normal diode and the moment it starts to conduct when the trigger pulse is applied.

Thus with a controlled 3-phase rectification which uses thyristors instead of diodes, we can control the value of the average DC output voltage by controlling the firing angle of the thyristor pairs and so the rectified output voltage becomes a function of the firing angle, α .

Therefore the only difference to the formula used above for the average output voltage of a 3-phase bridge rectifier is in the cosine angle, $\cos(\alpha)$ of the firing or triggering pulse. So if the firing angle is zero, ($\cos(0) = 1$), the controlled rectifier performs similar to the previous 3-phase uncontrolled diode rectifier with the average output voltages being the same.

UNIT-IV

CONTROLLED RECTIFIERS

SCR:

A silicon controlled rectifier or semiconductor-controlled rectifier is a four-layer solid state current-controlling device. The name "silicon controlled rectifier" is General Electric's trade name for a type of thyristor.

SCRs are mainly used in electronic devices that require control of high voltage and power. This makes them applicable in medium and high AC power operations such as motor control function.

An SCR conducts when a gate pulse is applied to it, just like a diode. It has four layers of semiconductors that form two structures namely; NPNP or PNPN. In addition, it has three junctions labeled as J1, J2 and J3 and three terminals anode, cathode and a gate. An SCR is diagrammatically represented as shown below.

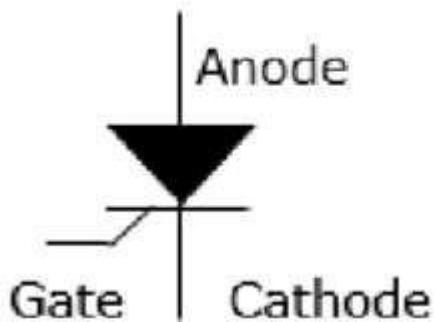

The anode connects to the P-type, cathode to the N-type and the gate to the P-type as shown below.

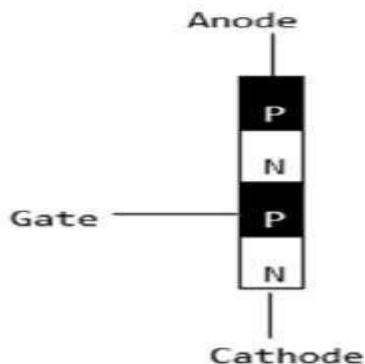

In an SCR, the intrinsic semiconductor is silicon to which the required dopants are infused. However, doping a PNPN junction is dependent on the SCR application.

MODES OF OPERATION IN SCR

- **OFF state** forward blocking mode: Here the anode is assigned a positive voltage, the gate is assigned a zero voltage disconnected and the cathode is assigned a negative voltage. As a result, Junctions J1 and J3 are in forward bias while J2 is in reverse bias. J2 reaches its breakdown avalanche value and starts to conduct. Below this value, the resistance of J1 is significantly high and is thus said to be in the off state.
- **ON state** conducting mode An SCR is brought to this state either by increasing the potential difference between the anode and cathode above the avalanche voltage or by applying a positive signal at the gate. Immediately the SCR starts to conduct, gate voltage is no longer needed to maintain the ON state and is, therefore, switched off by
 - Decreasing the current flow through it to the lowest value called holding current
 - Using a transistor placed across the junction.
- **Reverse blocking** – This compensates the drop in forward voltage. This is due to the fact that a low doped region in P1 is needed. It is important to note that the voltage ratings of forward and reverse blocking are equal.

TWO TRANSISTOR ANALOGY OF SCR:

Two transistor analogy of SCR is a method of representing SCR in the form of two transistor model. This represents SCR is the combination of PNP and NPN transistor.

SCR or thyristor is a three terminal semiconductor device which having P-N-P-N structure. The basic operating principle of SCR can understand by two transistor method of SCR.

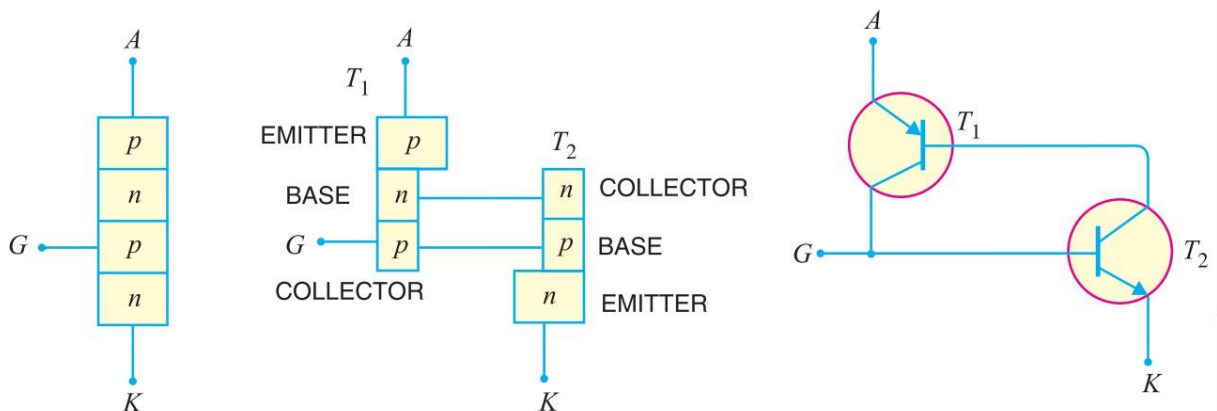

As per figure you can see **two transistors equivalent circuit of SCR**. From the figure, you can see the base of the transistor T1 is work as the collector of the transistor T2 and collector of the transistor T1 work as the base of the transistor T2.

Now here we find the expression for anode current of SCR.

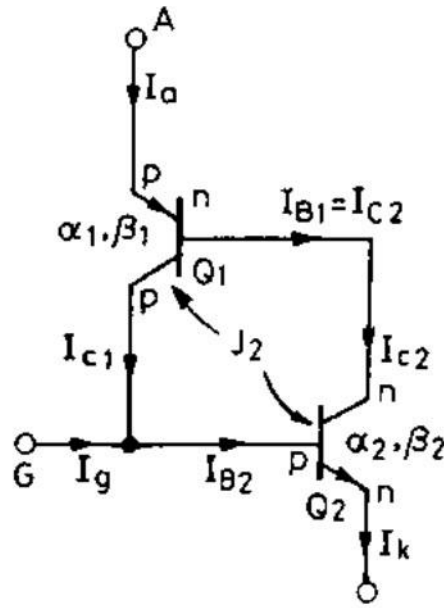
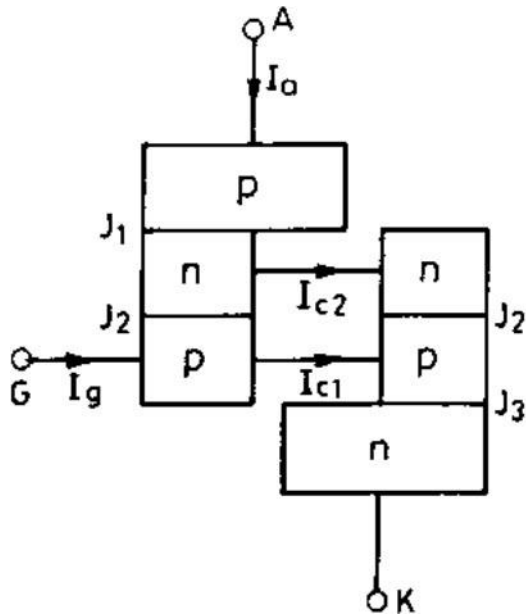

As per transistor leakage current equation,

Collector current is expressed as,

$$I_C = \alpha I_E + I_{CBO}$$

Where α is the current gain of transistor and I_{cbo} is the leakage current of the common base transistor.

For transistor T1 emitter current = anode current I_a and collector current $I_c = I_{c1}$

$$I_{C1} = \alpha_1 I_a + I_{CBO1}$$

Where α_1 is the current gain of transistor T1.

Similarly, for transistor T2

$$I_{C2} = \alpha_2 I_k + I_{CBO2}$$

Where α_2 is the current gain of transistor T2. And emitter current of transistor T2 = cathode current I_k .

Hereby figure, you can see anode current I_a is the sum of two collector current: I_{c1} and I_{c2} .

$$\therefore I_a = I_{C1} + I_{C2}$$

$$I_a = \alpha_1 I_a + I_{CBO1} + \alpha_2 I_k + I_{CBO2}$$

By putting $I_k = I_a + I_g$, anode current I_a will be,

$$I_a = \alpha_1 I_a + I_{CBO1} + \alpha_2 (I_a + I_g) + I_{CBO2}$$

$$I_a = \frac{\alpha_2 I_g + I_{CBO1} + I_{CBO2}}{1 - (\alpha_1 + \alpha_2)}$$

SCR WORKING WITH TWO TRANSISTOR MODEL

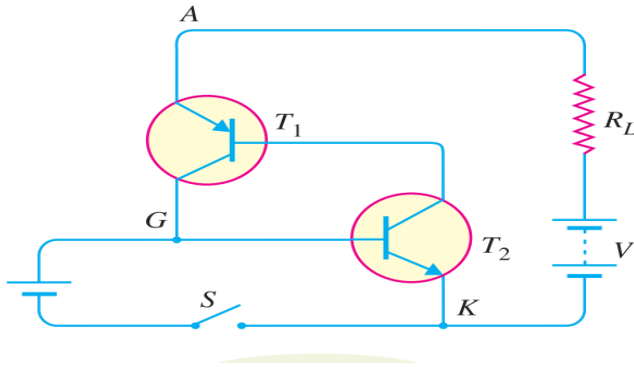

Working of the SCR can be easily explained by **two transistor model of SCR**. As per figure you can see with supply voltage V and load resistance R is applied to SCR. Here first Assume the supply voltage V is less than break over voltage as is usually the case. When the gate is open (i.e. switch S open), there is base current $I_b=0$. For the base of the T_2 is connected with the collector of The T_1 . Therefore, no current flows in the collector of T_2 and hence that of T_1 . So for this condition, SCR is in OFF condition.

Whenever switch S is closed, a small gate current will flow through the base of T_2 which means its collector current will increase. The collector of the transistor T_2 is connected with transistor T_1 . So, the collector current of T_2 is the base current of T_1 . Therefore, the collector current of T_1 increases. But collector current of T_1 is the base current of T_2 . This action is accumulative since an increase of current in one transistor causes an increase of current in the other transistor. As a result of this action, both transistors are driven to saturation, and heavy current flows through the load R_L . Under such conditions, the SCR closes.

TURN-ON LOSSES IN SCR (SILICON CONTROLLED RECTIFIER):

SCRs (Silicon Controlled Rectifiers) are semiconductor devices used for switching and controlling electrical power. Like other semiconductor devices, SCRs have turn-on and turn-off characteristics that affect their performance and efficiency.

Turn-on losses refer to the energy dissipated during the process of turning on an SCR, causing it to conduct current. When an SCR is triggered to switch from its non-conducting (off) state to its conducting (on) state, there is a momentary power dissipation associated with this transition. This occurs during the initial phase of conduction when the voltage across the SCR is reduced to a level where it becomes forward-biased.

The turn-on losses in an SCR are primarily due to:

1. **Forward Voltage Drop:** When an SCR turns on, there is a voltage drop across the device that depends on the SCR's forward voltage rating. This voltage drop is often referred to as the "on-state voltage" or "forward voltage" and results in power dissipation in the device. The forward voltage drop varies with the current passing through the SCR.
2. **Gate Triggering Energy:** In order to turn on an SCR, a gate signal is applied to the gate terminal. Some energy is consumed to trigger the SCR, and this energy may contribute to the turn-on losses. The gate triggering energy can vary depending on the triggering method used (e.g., voltage triggering, current triggering).

Turn-on losses are important to consider in SCR applications because they represent energy that is converted into heat. In high-power applications, these losses can lead to temperature rise, which may affect the SCR's performance and reliability.

THERMAL PROTECTION IN SCR:

In high-power applications, SCR devices generate heat due to conduction losses, turn-on and turn-off losses, and other factors. To ensure the safe and reliable operation of SCRs, thermal protection mechanisms are often incorporated. These mechanisms are designed to monitor the device's temperature and take action to prevent overheating.

Common thermal protection methods for SCRs include:

1. **Temperature Sensors:** SCRs are equipped with temperature sensors, such as thermistors or integrated temperature-sensing elements. These sensors monitor the temperature of the SCR.
2. **Thermal Shutdown:** When the temperature of the SCR exceeds a predefined threshold, the thermal protection system can trigger a shutdown mechanism. This may include turning off the SCR or reducing its current-carrying capacity to prevent overheating.
3. **Current Derating:** In response to increased temperature, some thermal protection systems may automatically reduce the rated current or load-carrying capacity of the SCR to prevent excessive temperature rise.
4. **Alarms and Notifications:** In some systems, thermal protection may trigger alarms or notifications to alert operators to the potential overheating issue. This provides an opportunity for corrective action to be taken.

Thermal protection is essential to prevent overheating, which can damage or degrade the performance of the SCR. Proper thermal management and protection mechanisms are critical in high-power SCR applications to ensure safe and reliable operation while extending the device's operational lifespan.

TWO PULSE CONVERTER

FULLY CONTROLLED BRIDGE CONVERTER

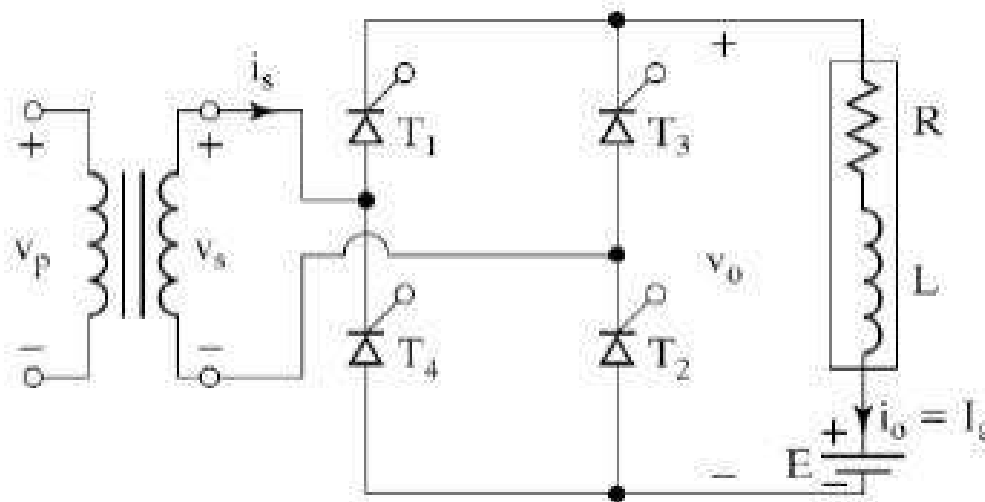

Figure 2.2.1 SINGLE PHASE FULL CONVERTER

CONSTRUCTION

The circuit diagram of a single phase fully controlled bridge converter is shown in the figure with a highly inductive load and a dc source in the load circuit so that the load current is continuous and ripple free (constant load current operation). The fully controlled bridge converter consists of four thyristors T_1 , T_2 , T_3 and T_4 connected in the form of full wave bridge configuration as shown in the figure. Each thyristor is controlled and turned on by its gating signal and naturally turns off when a reverse voltage appears across it.

During the positive half cycle when the upper line of the transformer secondary winding is at a positive potential with respect to the lower end the thyristors T_1 and T_2 are forward biased during the time interval

$\omega t = 0$ to π . The thyristors T1 and T2 are triggered simultaneously $\omega t = \alpha$; ($0 \leq \alpha \leq \pi$), the load is connected to the input supply through the conducting thyristors T1 and T2. Due to the inductive load T1 and T2 will continue to conduct beyond $\omega t = \pi$, even though the input voltage becomes negative. T1 and T2 conduct together during the time period α to $(\pi + \alpha)$, for a time duration of π radians (conduction angle of each thyristor = 180°).

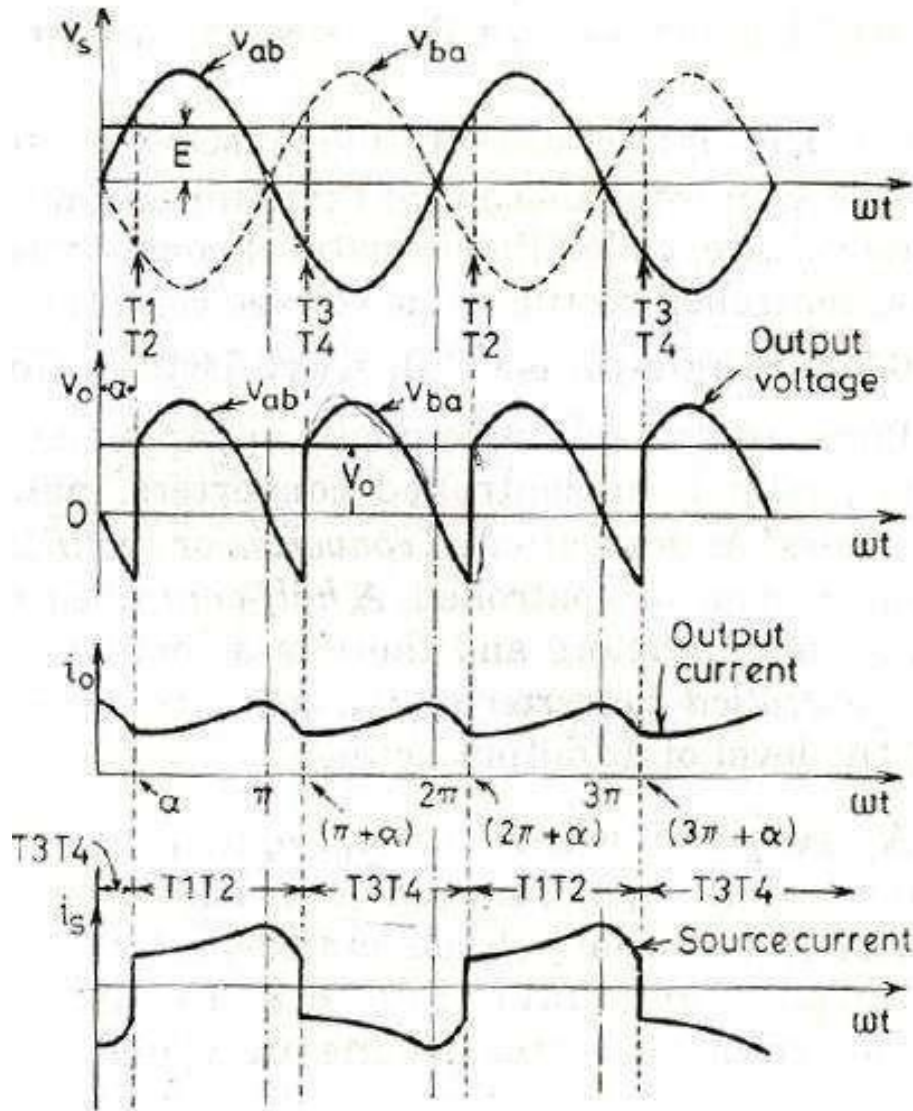

Figure 2.2.2 FULL CONVERTER WAVEFORM

/

During the negative half cycle of input supply voltage for $\omega t = \pi$ to 2π the

thyristors T3 and T4 are forward biased. T3 and T4 are triggered at $\omega t = (\pi + \alpha)$. As soon as the thyristors T3 and T4 are triggered a reverse voltage appears across the thyristors T1 and T2 and they naturally turn-off and the load current is transferred from T1 and T2 to the thyristors T3 and T4. In the next positive half cycle when T1 and T2 are triggered, T3 and T4 are reverse biased and they turn-off. The figure shows the waveforms of the input supply voltage, the output load voltage, the constant load current with negligible ripple and the input supply current.

During the time period $\omega t = \alpha$ to π , the input supply voltage V_S and the input supply current is both positive and the power flows from the supply to the load. The converter operates in the rectification mode during $\omega t = \alpha$ to π .

During the time period $\omega t = \pi$ to $(\pi + \alpha)$, the input supply voltage V_S is negative and the input supply current is positive and there will be reverse power flow from the load circuit to the input supply. The converter operates in the inversion mode during the time period $\omega t = \pi$ to $(\pi + \alpha)$ and the load energy is fed back to the input source.

The single phase full converter is extensively used in industrial applications up to about 15kW of output power. Depending on the value of trigger angle α , the average output voltage may be either positive or negative and two quadrant operation is possible.

TWO PULSE HALF CONTROLLED BRIDGE CONVERTER:

A Two pulse half controlled bridge converter is obtained by connecting a two pulse controlled midpoint converter in series with an uncontrolled one, as shown in Fig. 3.45. The controlled converter has thyristors T_1 and T_2 in a common cathode connection whereas the uncontrolled one has diodes D_1 and D_2 in a common anode connection. The former is a positive group and the latter a negative group. The bridge can also be obtained with the uncontrolled converter in the positive group and the controlled one in the negative group.

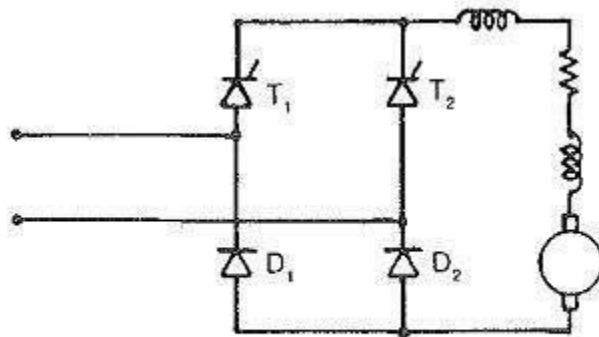

Fig. 3.45 Two pulse half controlled bridge converter (symmetrical connection)

The voltage of the controlled converter can be varied from positive maximum to negative maximum by changing the phase angle from 0 to 180°. The output voltage of the uncontrolled bridge is constant. The net voltage at the load terminals is the sum of the voltages of the controlled and uncontrolled groups. The average voltage varies from a maximum value to zero. The output voltage cannot reverse its polarity, due to the uncontrolled bridge. Only rectification is possible.

Taking the inverter limit of the controlled group into consideration, the phase angle can be varied from 0 to near about 180°. The average dc voltage varies from a maximum value to near about zero. Because of the inverter limit of the controlled converter, zero voltage is not possible.

The average value of the voltage at the dc terminals is given by

$$V_{dca} = \frac{V_{dio}}{2} (1 + \cos \alpha) \quad (3.69)$$

where

$$V_{dio} = \frac{2\sqrt{2}V_L}{\pi}$$

The control characteristic is shown in Fig. 3.46, wherein the inverter limit is indicated.

For inductive loads there is an inherent free wheeling action provided by the incoming diode and the reverse biased thyristor, until the incoming thyristor is turned on. Referring to Fig. 3.47, the thyristor T₁ and the diode D₂ conduct during the positive half cycle while T₂ and D₁ do so in the next half cycle.

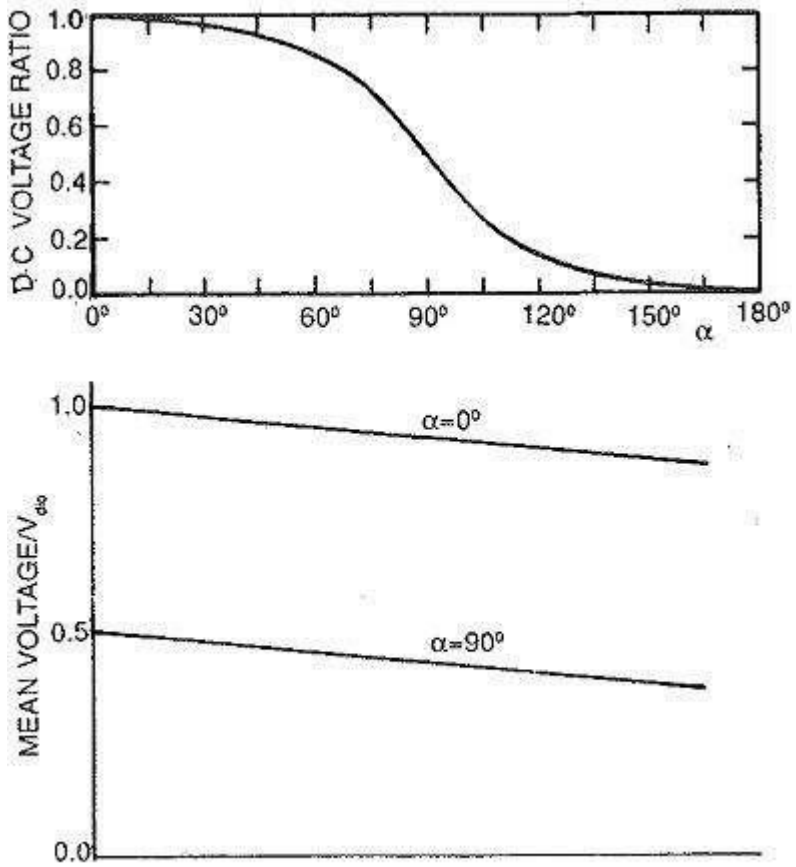

Fig. 3.46 *Control characteristic and regulation*

There are also periods of time where T_1D_1 or T_2D_2 conduct simultaneously. The load current free wheels and mains are relieved from supplying the current when the devices placed diagonally opposite conduct, the supply voltage appears across the load. The current flows from the supply to the load. When the devices connected in series conduct, the load voltage is zero and the load current free wheels.

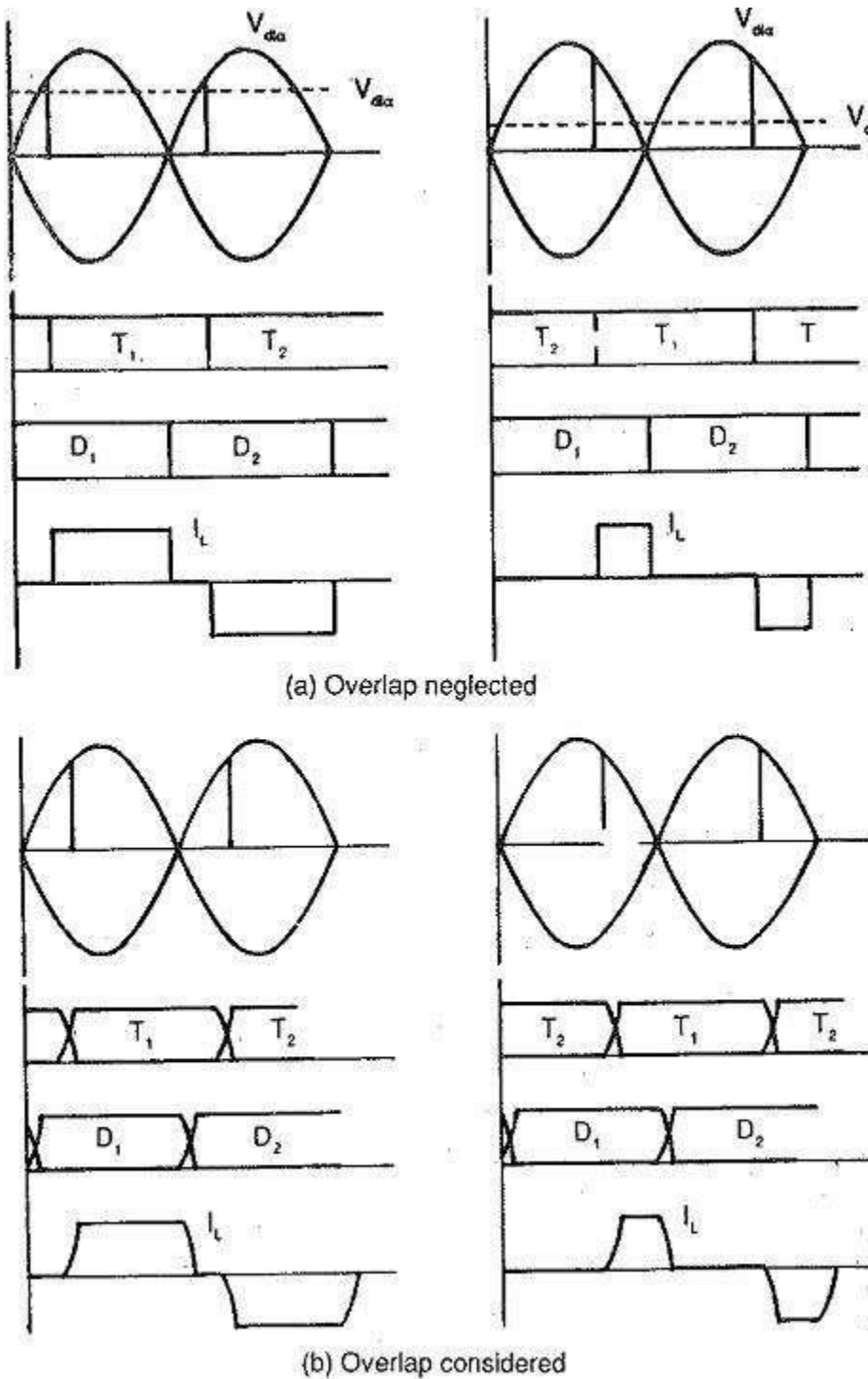

Fig. 3.47 Voltage and current waveforms

To start with let us assume that T_1 and D_2 are conducting. The portion of the positive half cycle appears across the load (α to π). At $\omega t = \pi$, D_1 gets forward biased and the current transfers from D_2 to D_1 . D_2 to T_1 continues to conduct till T_2 is fired at appropriate firing angle $[\alpha + \pi]$. Current transfers from T_1 to T_2 . Now T_2 and D_1 conduct. The supply voltage appears across the load. Thus the thyristor is in conduction for 180° . There is an inherent free wheeling action because of the diodes, and this makes the voltage across the load zero. The negative excursions of the load voltage are prevented by the uncontrolled bridge.

The output voltage in the working range is affected by the device drops in the forward directions, as well as the resistance drops. The reactances in the line side of the converter are responsible for overlap. The current transfer takes place in a definite amount of time. The rate of change of current combined with the reactances causes a voltage drop. This can be determined in the same way as for a fully controlled converter. Therefore

$$V_d = V_{d\alpha} - D_x - I_d R - (V_T + V_D) \quad (3.70)$$

$$V_d = \frac{V_{dio}}{2} (1 + \cos \alpha); \quad D_x = \frac{V_{dio}}{2} (\cos \alpha - \cos(\alpha + u)) \quad (3.71)$$

For Very small firing angles and highly inductive loads, it is not possible to turn off the converter in this connection by a sudden removal of firing pulses. The last thyristor fired remains in conduction indefinitely, making the input voltage appear across the dc terminals every other half cycle. For example, assume that at some instant of time T_1 and D_2 are conducting and instant the firing pulses are removed. When T_1 is reverse biased, the natural free wheeling through T_1 and D_1 maintains the current in the load and the load voltage is zero. If the current has not decayed to zero during this time, the thyristor T_1 gets a forward voltage and conducts as if $\alpha = 0$. The positive half cycle of voltage appears across the load and the load current flows through T_1 and D_2 for the complete half cycle. This phenomenon is called half waving. To turn off the converter is to maintain the gate pulses and retard the firing angle such that the load voltage is reduced. Consequently the load current falls below the holding current of the thyristor.

The elimination of the negative excursions of dc voltage due to natural free wheeling is advantageous, in that the superimposed ac ripple on the average dc voltage decreases with reduced smoothing equipment.

It can also be observed from the current waveforms that the period of conduction of the input current pulses decreases as the firing angle is retarded, i.e. output voltage is reduced. Thus the reactive power requirements of a half controlled bridge are considerably less than those of the fully controlled one at reduced voltage. The rms value of the input current

$$I_s = I_d \sqrt{1 - \frac{\alpha}{\pi}} \quad (3.72)$$

The fundamental displacement factor is $\cos \alpha/2$. The saving in control reactive power is considerable, as the free wheeling action takes place even at $\alpha = \pi$. However there is no saving in commutation reactive power.

The periods of current flow in the thyristor and diode are equal. The peak forward or reverse voltage of the devices is equal to

$$\sqrt{2}V_L \quad \text{or} \quad \frac{V_{dio}}{2\pi}$$

The harmonic components of the input current depend upon the control angle. They have different spectrum at different α . Therefore the value of g depends upon α . The total power factor is

$$\lambda = g \cos \alpha/2 = \frac{2\sqrt{2}}{\pi} \frac{\cos^2 \alpha/2}{\sqrt{1 - \alpha/\pi}} \quad (3.73)$$

The ripple content in the output voltage is reduced because of the inherent free wheeling action, which prevents the negative excursions of the output voltage. The amount of smoothing inductance in the load circuit is small it is only 57% of the value required with a fully controlled converter. The performance of the converter is summarised in Fig. 3.48.

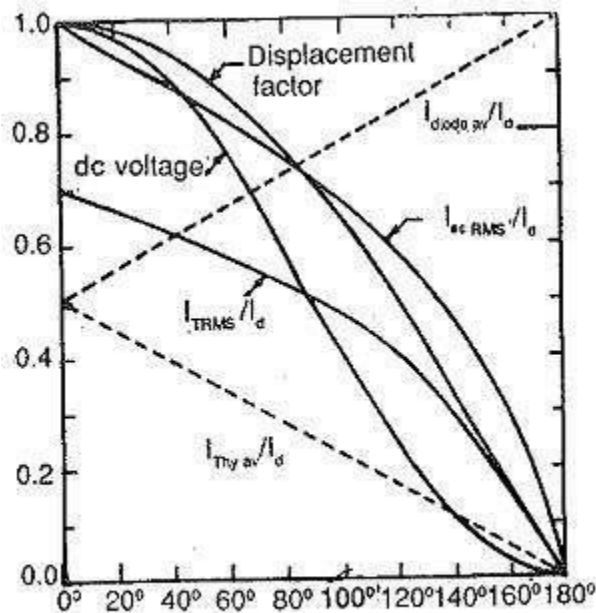

Fig. 3.48 Performance characteristics

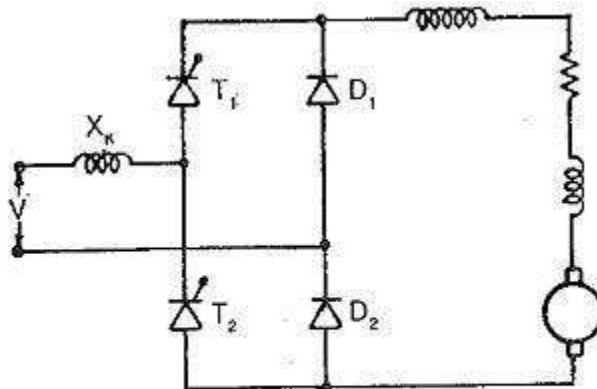

Fig. 3.49 Two pulse half controlled asymmetrical bridge converter

The other possible Two pulse half controlled bridge converter connection is as shown in Fig. 3.49. This is a symmetrical connection. The voltage and current waveforms of the converter are shown in Fig. 3.50.

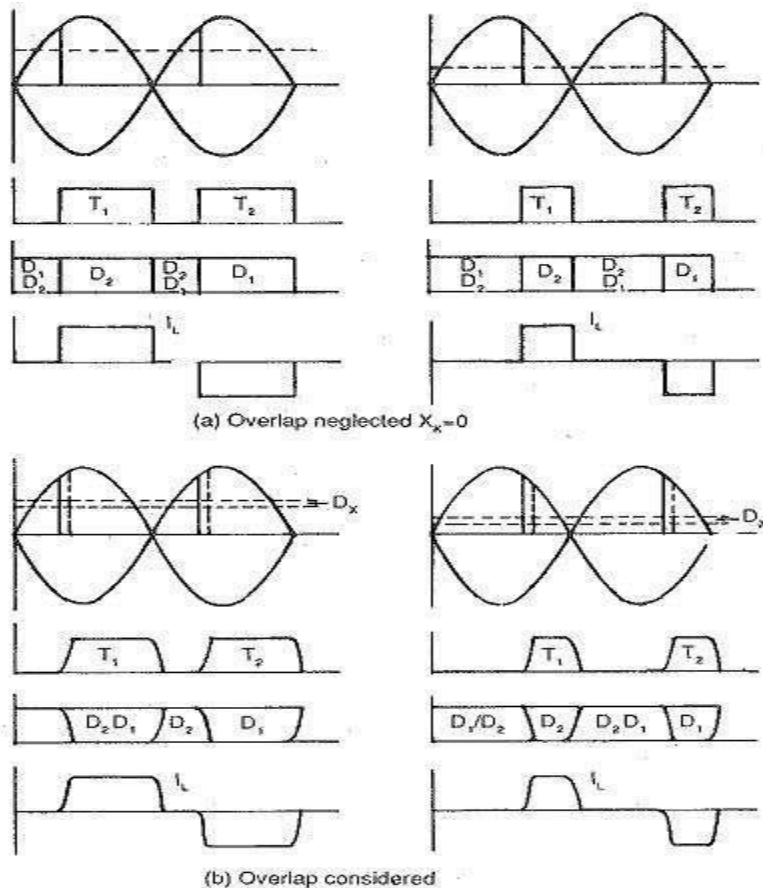

Fig. 3.50 Voltage and current waveforms of a half controlled asymmetrical two pulse circuit

The free wheeling is provided by the diodes D_1 D_2 . The thyristor T_1 and diode D_2 conduct in the positive half cycle and T_2 and D_1 in the negative half cycle. At the end of the positive half cycle, D_2 acquires a positive voltage and D_1 D_2 free wheel the load current. This free wheeling prevents the negative portions from appearing in the output voltage. The operation and behaviour of the circuit is the same as the previous circuit as far as the output voltage, power factor, etc. are concerned. However there are two differences. First, the half waving of the circuit is not present. From the waveforms of the current, it can be seen that as α increases the period of conduction of the thyristor decreases and that of the diode increases. The devices can, therefore, be rated accordingly depending upon their maximum period of conduction. The period of the input current pulses decreases as α is delayed.

APPLICATIONS OF TWO PULSE HALF CONTROLLED BRIDGE CONVERTER:

Two pulse half controlled bridge converter of large power find application in tram cars in which single phase power is rectified to feed the traction motor. In these applications one tries to improve the reactive power saving without giving much importance to regenerative braking.

THREE PULSE CONVERTER

INTRODUCTION TO 3-PHASE CONTROLLED RECTIFIERS

Three phase converters are 3-phase controlled rectifiers which are used to convert ac input power supply into dc output power across the load.

FEATURES OF 3-PHASE CONTROLLED RECTIFIERS ARE

- ❖ Operate from 3 phase ac supply voltage.
- ❖ They provide higher dc output voltage and higher dc output power.
- ❖ Higher output voltage ripple frequency.
- ❖ Filtering requirements are simplified for smoothing out load voltage and load current. Three phase controlled rectifiers are extensively used in high power variable speed industrial dc drives.

3-PHASE HALF WAVE CONVERTER WITH R LOAD (THREE PULSE CONVERTER)

Three single phase half-wave converters are connected together to form a three phase half-wave converter as shown in the figure.

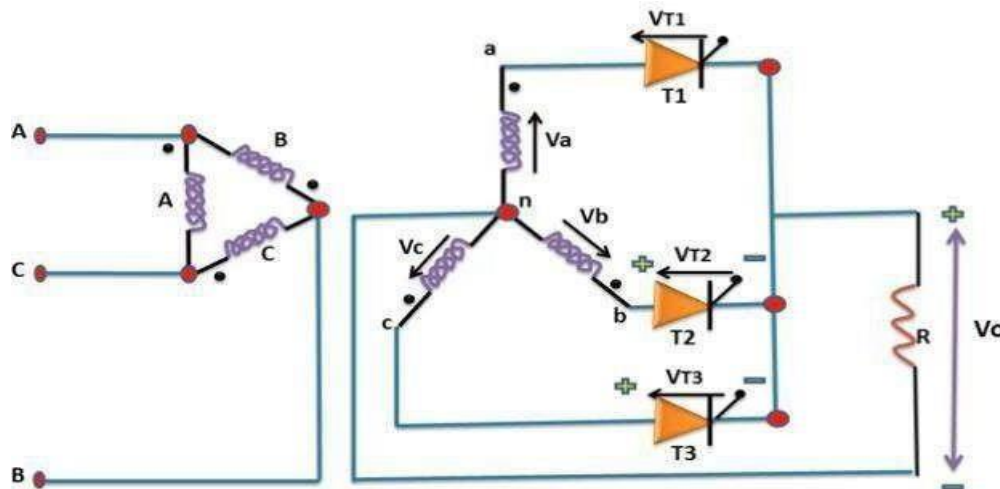

Figure 2.3.1 Three pulse converter circuit diagram

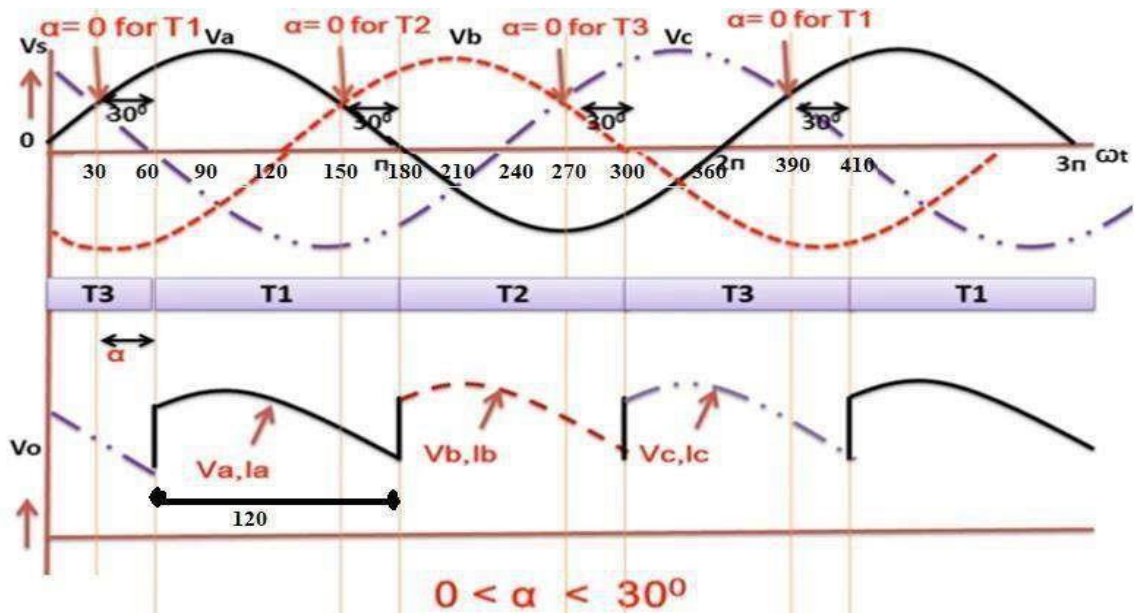

Figure 2.3.2 Three pulse converter Waveforms

The 3-phase half wave converter combines three single phase half wave controlled rectifiers in one single circuit feeding a common load. The thyristor T1 in series with one of the supply phase windings 'a - n' acts as one half wave controlled rectifier. The second thyristor T2 in series with the supply phase winding, 'b - n' acts as the second half wave controlled rectifier. The third thyristor T3 rectifier in series with the supply phase winding 'c - n' acts as the third half wave controlled.

The 3-phase input supply is applied through the star connected supply transformer as shown in the figure. The common neutral point of the supply is connected to one end of the load while the other end of the load connected to the common cathode point. When the thyristor T 1 is triggered the load current flows through the supply phase winding 'a - n' and through thyristor T1 as long as T1 conducts.

When thyristor T 2 is conducts the phase voltage V_{bn} appears across the load until the thyristor T3 is triggered . When the thyristor T3 is triggered the phase voltage V_{cn} appears across the load.

For a purely resistive load where the load inductance ' $L = 0$ ' and the current appears as discontinuous.

The frequency of output ripple frequency for a 3-phase half wave converter is $3f_s$, where f_s is the input supply frequency.

The 3-phase half wave converter is not normally used in practical converter systems because of the disadvantage that the supply current waveforms contain dc components.

SIX PULSE CONVERTER

THREE PHASE FULL CONVERTER

Three phase full converter is a fully controlled bridge controlled rectifier using six thyristors connected in the form of a full wave bridge configuration. All the six thyristors are controlled switches which are turned on at a appropriate times by applying suitable gate trigger signals.

FEATURES OF 3-PHASE CONTROLLED RECTIFIERS ARE

- ❖ They provide higher dc output voltage and higher dc output power.
- ❖ Higher output voltage ripple frequency.
- ❖ Three phase controlled rectifiers are extensively used in highpower variable speed industrial dc drives.

THREE PHASE FULLY CONTROLLED BRIDGE CONVERTER

The three phase fully controlled bridge converter has been probably the most widely used power electronic converter in the medium to high power applications. Three phase circuits are preferable when large power is involved. The controlled rectifier can

provide controllable output dc voltage in a single unit instead of a three phase autotransformer and a diode bridge rectifier. The controlled rectifier is obtained by replacing the diodes of the uncontrolled rectifier with thyristors. Control over the output dc voltage is obtained by controlling the conduction interval of each thyristor. This method is known as phase control and converters are also called “phase controlled converters”. Since thyristors can block voltage in both directions it is possible to reverse the polarity of the output dc voltage and hence feed power back to the ac supply from the dc side. Under such condition the converter is said to be operating in the “inverting mode”. The thyristors in the converter circuit are commutated with the help of the supply voltage in the rectifying mode of operation and are known as “Line commutated converter”. The same circuit while operating in the inverter mode requires load side counter emf. for commutation and are referred to as the “Load commutated inverter”.

A three phase fully controlled converter is obtained by replacing all the six diodes of an uncontrolled converter by six thyristors as shown in Fig.

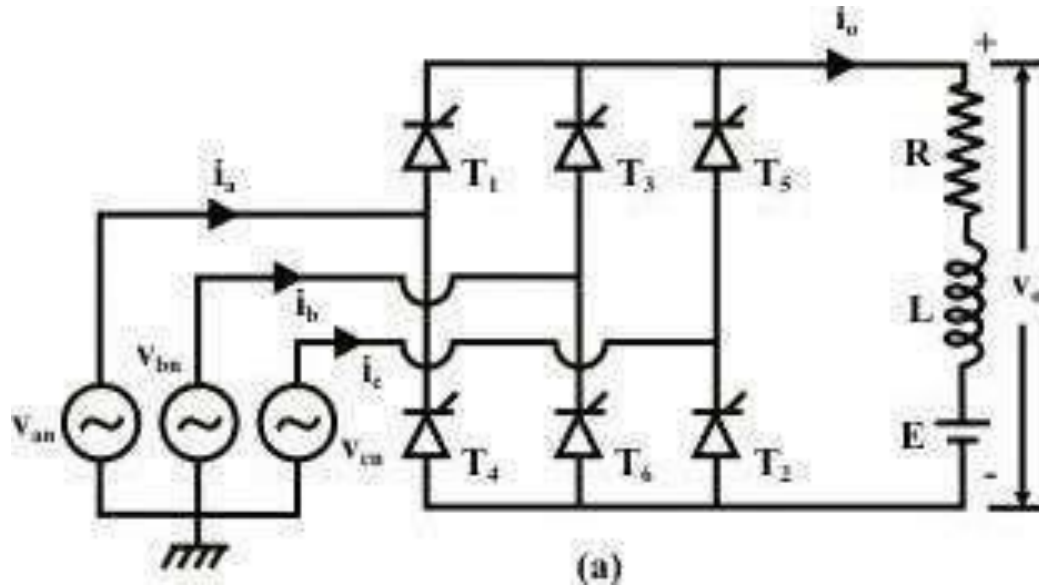

Figure 2.4.1 Six pulse converter

- The three thyristors (T1 ,T3 andT5) will not work together at the sametime or two of themalso will not work together at the same time.
- The three thyristors (T2 ,T4 andT6) will not work together at the sametime or two of themalso will not work together at the same time.
- (T1 and T4), (T3 and T6) or (T5 and T2) will not work together at the sametime.
- Each thyristor is triggered at an interval of $2\pi / 3$.
- Each thyristors pair ((T6&T1), (T1&T2), (T2&T3), (T3&T4), (T4&T5), (T5&T6)) is triggered at an interval of $\pi / 3$.

The frequency of output ripple voltage is $6f_s$.

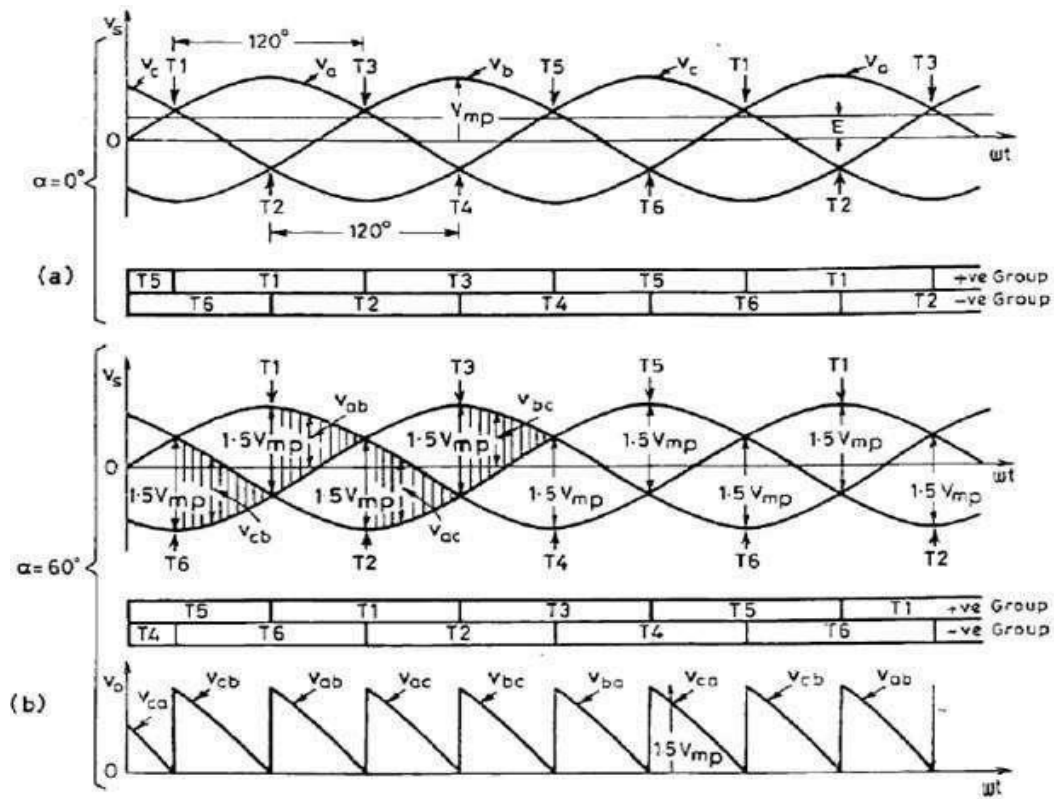

Figure 2.4.2 Six pulse converter Waveforms

- If T1 is triggered at $(30 + \alpha)$, T3 will be triggered at $(30 + \alpha + 120)$ and T5 will be triggered at $(30 + \alpha + 240)$. T4 will be triggered at $(30 + \alpha + 180)$, T6 will be triggered at $(30 + \alpha + 120 + 180)$ and T2 will be triggered at $(30 + \alpha + 240 + 180)$.

Firing Angle	T1	T2	T3	T4	T5	T6
0°	30°	90°	150°	210°	270°	330°
30°	60°	120°	180°	240°	300°	360°
60°	90°	150°	210°	270°	330°	390°
90°	120°	180°	240°	300°	360°	420°

Three phase full converter – triggering angles of thyristor

At $\omega t = 30^\circ + \alpha$, thyristor T6 is already conducting when the thyristor T1 is turned on by applying the gating signal to the gate of T1. During the time period $\omega t = 30^\circ + \alpha$ to $90^\circ + \alpha$ thyristors T1 and T6 conduct together and the line to line supply voltage V_{ab} appears across the load. At $\omega t = 90^\circ + \alpha$, the thyristor T2 is triggered and T6 is reverse biased immediately and T6 turns off due to natural commutation. During the time period $\omega t = 90^\circ + \alpha$ to $150^\circ + \alpha$, thyristor T1 and T2 conduct together and the line to line supply voltage V_{ac} appears across the load. The thyristors are numbered in the circuit diagram corresponding to the order in which they are triggered.

EFFECT OF SOURCE INDUCTANCE

In actual practice, the converter is connected to ac mains through a transformer.

In a converter, because of source inductance, the current in the outgoing thyristor cannot change from full value to zero instantaneously and the current through the incoming thyristor cannot increase from zero to full value instantaneously. Therefore after the triggering gate pulse is applied to a thyristor, the current of the outgoing thyristor decreases from full value to zero over a time $\omega t = \mu$. During this time interval the current through incoming thyristor rises from zero to full value. During this period μ known as commutating period, both the outgoing and incoming thyristors are conducting. μ is also known as overlap angle. The

overlapping of currents causes a reduction in output voltage. During this commutation period, the output voltage is equal to 0.

Figure shows a single phase fully controlled bridge converter with source inductance L_s . The load is assumed to be highly inductive so that load current can be assumed to be constant and equal to I_0 . Let i_1 and i_2 be the currents through Th1, Th2 combination and Th3, Th4 combination respectively.

During overlap period μ one of these currents decays to zero and the other builds up from zero to full value. Four thyristors conduct together as shown in Fig

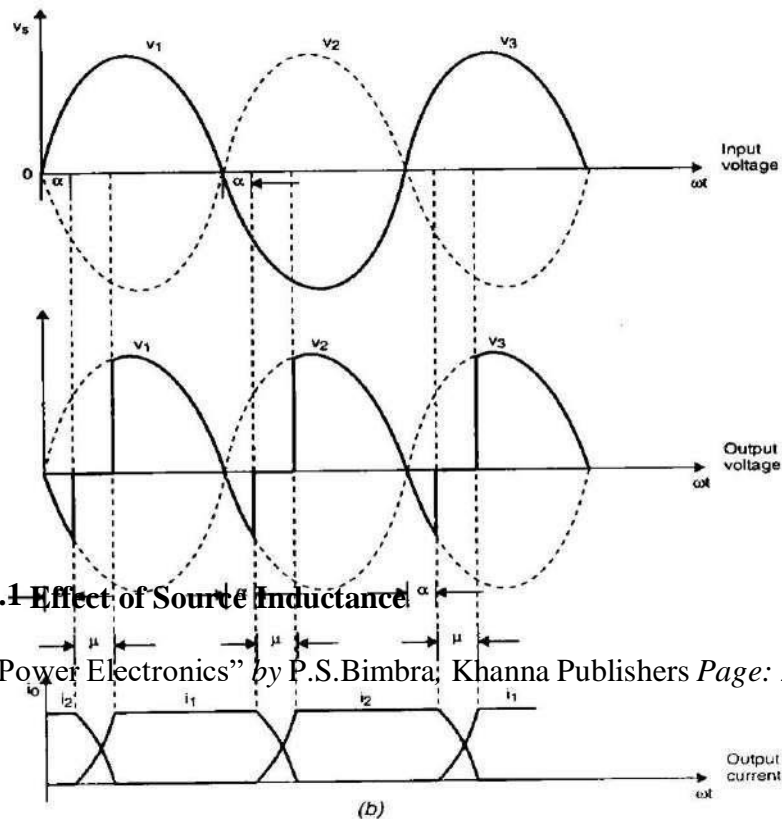

Figure 2.6.1 Effect of Source Inductance

[Source: "Power Electronics" by P.S.Bimbra; Khanna Publishers Page: 223]

THE INVERTER ANGLE LIMIT:

The inverter angle limit in a controlled converter, typically referred to as the "firing angle" or "commutation angle," is a crucial parameter that determines when the controlled switches (such as thyristors or IGBTs) in the converter are triggered to turn on and off. The firing angle dictates the

phase angle at which the converter begins to conduct and, therefore, controls the power flow and the output voltage waveform.

In applications like rectifiers and inverters, the firing angle is adjusted to regulate the output voltage or current. For an inverter, the firing angle is used to control the magnitude and frequency of the output AC voltage. Here are some key points to understand about the inverter angle limit in a controlled converter:

1. **FIRING ANGLE RANGE:** The firing angle typically varies between 0 and 180 degrees in single-phase systems and between 0 and 120 degrees in three-phase systems. The firing angle specifies the delay between the zero-crossing point of the input AC voltage and the point at which the controlled switch is triggered to conduct.
2. **CONTROL STRATEGY:** The choice of firing angle is part of the control strategy. By adjusting the firing angle, the converter can produce an output waveform that varies in magnitude, frequency, and waveform shape. This is commonly used in motor drives, induction heating, and other power electronics applications.
3. **VOLTAGE CONTROL:** In inverters, the firing angle is used to control the amplitude of the output voltage. A smaller firing angle results in a higher average voltage and vice versa. By modulating the firing angle, the inverter can generate a variable AC voltage.
4. **FREQUENCY CONTROL:** In three-phase systems, the firing angle can also be used to control the output frequency. By varying the firing angles of the thyristors or other controlled switches in the inverter, you can change the frequency of the generated AC waveform. This is often used in variable frequency drives (VFDs) for controlling the speed of AC motors.
5. **PHASE ANGLE CONTROL:** In applications where phase angle control is used, the firing angle is adjusted to control the phase relationship between the input and output voltages, which can be important for power factor correction and other applications.
6. **HARMONIC CONTROL:** Care must be taken when choosing the firing angle to minimize harmonic distortion in the output voltage. The selection of the firing angle affects the harmonic content of the output waveform, and this can impact the quality of power in the system.

In summary, the inverter angle limit or firing angle in a controlled converter plays a critical role in regulating the output voltage, frequency, and phase relationship. Careful control of the firing angle is necessary to achieve the desired output characteristics and to minimize harmonic distortion in the system. The specific application and control requirements will determine the optimal firing angle for the converter.

UNIT-V

AC PHASE CONTROLLERS

TRIAC:

A **Triac** is defined as a three terminal AC switch which is different from the other silicon controlled rectifiers in the sense that it can conduct in both the directions that is whether the applied gate signal is positive or negative, it will conduct. Thus, this device can be used for AC systems as a switch.

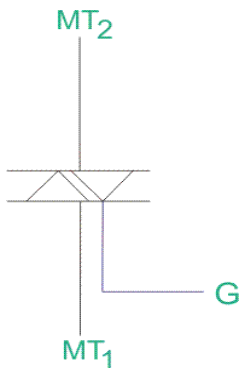

The triac can be turned on by applying the gate voltage higher than break over voltage. However, without making the voltage high, it can be turned on by applying the gate pulse of 35 micro seconds to turn it on. When the voltage applied is less than the break over voltage, we use gate triggering method to turn it on.

There are four different modes of operations, they are-

1. When MT_2 and Gate being Positive with Respect to MT_1
When this happens, current flows through the path $P_1-N_1-P_2-N_2$. Here, P_1-N_1 and P_2-N_2 are forward biased but N_1-P_2 is reverse biased. The triac is said to be operated in positively biased region. Positive gate with respect to MT_1 forward biases P_2-N_2 and breakdown occurs.
2. When MT_2 is Positive but Gate is Negative with Respect to MT_1
The current flows through the path $P_1-N_1-P_2-N_2$. But P_2-N_3 is forward biased and current carriers injected into P_2 on the triac.
3. When MT_2 and Gate are Negative with Respect to MT_1
Current flows through the path $P_2-N_1-P_1-N_4$. Two junctions P_2-N_1 and P_1-N_4 are forward biased but the junction N_1-P_1 is reverse biased. The triac is said to be in the negatively biased region.
4. When MT_2 is Negative but Gate is Positive with Respect to MT_1
 P_2-N_2 is forward biased at that condition. Current carriers are injected so the triac turns on. This mode of operation has a disadvantage that it should not be used for high (di/dt) circuits. Sensitivity of triggering in mode 2 and 3 is high and if marginal triggering capability is required, negative gate pulses should be used. Triggering in mode 1 is more sensitive than mode 2 and mode 3.

CHARACTERISTICS OF A TRIAC

The **triac** characteristics is similar to SCR but it is applicable to both positive and negative triac voltages. The operation can be summarized as follows-

FIRST QUADRANT OPERATION OF TRIAC

Voltage at terminal MT_2 is positive with respect to terminal MT_1 and gate voltage is also positive with respect to first terminal.

SECOND QUADRANT OPERATION OF TRIAC

Voltage at terminal 2 is positive with respect to terminal 1 and gate voltage is negative with respect to terminal 1.

THIRD QUADRANT OPERATION OF TRIAC

Voltage of terminal 1 is positive with respect to terminal 2 and the gate voltage is negative.

FOURTH QUADRANT OPERATION OF TRIAC

Voltage of terminal 2 is negative with respect to terminal 1 and gate voltage is positive.

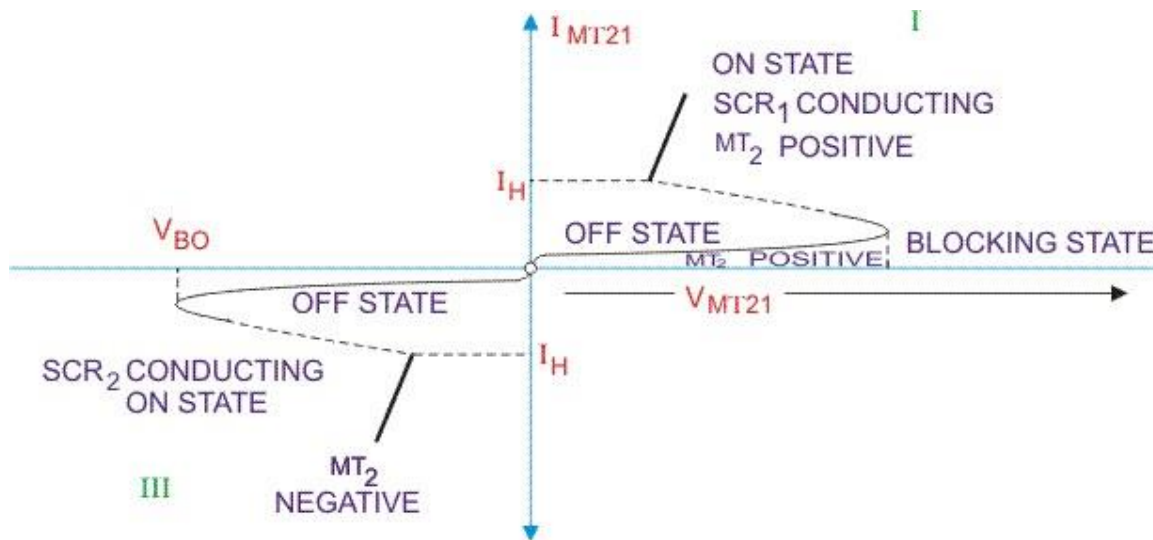

V-I Characteristic of a Triac

When the device gets turned on, a heavy current flows through it which may damage the device, hence in order to limit the current a current limiting resistor should be connected externally to it. By applying proper gate signal, firing angle of the device may be controlled. The gate triggering circuits should be used for proper gate triggering. We can use diac for triggering the gate pulse. For firing of the device with proper firing angle, a gate pulse may be applied up to a duration of 35 micro seconds.

ADVANTAGES OF TRIAC

1. It can be triggered with positive or negative polarity of gate pulses.
2. It requires only a single heat sink of slightly larger size, whereas for SCR, two heat sinks should be required of smaller size.
3. It requires single fuse for protection.
4. A safe breakdown in either direction is possible but for SCR protection should be given with parallel diode.

DISADVANTAGES OF TRIAC

1. They are not much reliable compared to SCR.
2. It has (dv/dt) rating lower than SCR.
3. Lower ratings are available compared to SCR.
4. We need to be careful about the triggering circuit as it can be triggered in either direction.

USES OF TRIAC

1. They are used in control circuits.
2. It is used in High power lamp switching.
3. It is used in AC power control.

A TRIAC-BASED PHASE CONTROLLER

A triac-based phase controller is a device used to control the power delivered to resistive loads, such as incandescent lamps or heaters, by adjusting the phase angle of the AC voltage applied to the load. This control is typically achieved by using a triac, which is a semiconductor device that can conduct current in both directions when triggered.

Here's how a triac-based phase controller works:

1. **Triac:** The central component of the phase controller is the triac (triode for alternating current). It is a bidirectional thyristor that can be triggered to start conducting current in either the positive or negative half-cycles of an AC voltage waveform.
2. **Triggering Circuit:** The phase controller includes a triggering circuit that determines when to activate the triac. This circuit can be controlled by various methods, such as a potentiometer, microcontroller, or external signals, depending on the application.
3. **Phase Angle Control:** The triggering circuit adjusts the timing at which the triac is triggered within each AC cycle. By delaying the point at which the triac turns on in each half-cycle, the effective power delivered to the load is reduced. This is often referred to as phase angle control or phase-cut control. The more the phase angle is delayed, the less power is delivered to the load.
4. **Load Connection:** The load (e.g., a light bulb or heater) is connected in series with the triac. When the triac is triggered, it allows current to flow through the load, and the power delivered to the load is determined by the phase angle at which the triac is triggered.

5. **Dimming or Temperature Control:** Triac-based phase controllers are commonly used for applications like dimming lights or controlling the temperature of heaters. By adjusting the phase angle, you can control the brightness of a lamp or the temperature of a heater.

Triac-based phase controllers are simple and cost-effective devices for controlling power to resistive loads. However, they are not suitable for controlling inductive loads or loads with power factor correction, as they may cause electromagnetic interference and other issues in such applications. For inductive loads, other types of AC voltage control, such as pulse-width modulation (PWM), may be more appropriate.

CONFIGURATIONS FOR SCR-BASED SINGLE-PHASE CONTROLLERS:

Silicon Controlled Rectifiers (SCRs) are semiconductor devices that can be used for power control in various applications. When used as single-phase controllers, SCRs are often employed in different configurations to control the power supplied to resistive or inductive loads. Here are some common configurations for SCR-based single-phase controllers:

1. **SINGLE-PHASE HALF-WAVE CONTROLLER:**
 - This is the simplest configuration, where an SCR is used to control power to a load by triggering it during only one half-cycle of the AC waveform.
 - It is suitable for purely resistive loads and provides basic on-off control.
 - Not efficient for controlling power to inductive loads due to abrupt current changes.
2. **SINGLE-PHASE FULL-WAVE CONTROLLER (TWO SCRS):**
 - In this configuration, two SCRs are used, one for each half-cycle of the AC waveform.
 - It provides better control and efficiency for both resistive and slightly inductive loads.
 - Commonly used for applications like dimming incandescent lamps or controlling the speed of universal motors.
3. **SINGLE-PHASE FULL-WAVE BRIDGE CONTROLLER:**
 - A full-wave bridge configuration uses four SCRs arranged in a bridge topology.
 - It provides better control and efficiency compared to the two SCR full-wave controller.
 - Suitable for a wide range of loads, including resistive and inductive loads.
 - Commonly used in applications like motor control and temperature regulation.
4. **R-C FIRING CIRCUIT CONTROLLER:**
 - In addition to the SCR configuration, a triggering circuit with an R-C network is used.
 - This circuit allows precise control of the SCR firing angle, which can be used for various applications, including light dimming and temperature control.
5. **PHASE-LOCKED LOOP (PLL) CONTROLLED SCR CONTROLLER:**
 - In this advanced configuration, a PLL is used to synchronize the firing angle of the SCR with the AC waveform.

- It offers highly precise control and is commonly used in applications requiring very accurate voltage or power regulation.
6. **FEEDBACK-CONTROLLED SCR CONTROLLER:**
 - This configuration includes feedback loops that measure load conditions, such as temperature or voltage, and adjust the firing angle of the SCR accordingly to maintain a desired setpoint.
 - Used in applications like temperature controllers, voltage regulators, and power factor correction.
 7. **SOFT STARTER CONFIGURATION:**
 - In some motor control applications, SCRs are used as soft starters to gradually increase the voltage and current supplied to the motor, reducing inrush current and mechanical stress during startup.

The choice of SCR controller configuration depends on the specific application and the type of load being controlled. Each configuration has its advantages and limitations, and the selection should consider factors such as load characteristics, precision requirements, efficiency, and cost.

CONFIGURATIONS FOR SCR-BASED THREE-PHASE CONTROLLERS

Three-phase SCR (Silicon Controlled Rectifier) controllers are commonly used for power control in industrial applications where three-phase AC power needs to be adjusted for various purposes. Here are various configurations for SCR-based three-phase controllers:

1. **STAR (WYE) CONFIGURATION:**
 - In the star or wye configuration, each SCR is connected in series with one phase of the load, and the three SCR anodes are joined at a common neutral point.
 - It is a commonly used configuration for controlling balanced three-phase resistive loads.
 - Suitable for applications like electric heaters, ovens, and lighting systems.
2. **DELTA CONFIGURATION:**
 - In the delta configuration, each SCR is connected in series with one phase of the load, and the SCR anodes are interconnected in a delta (triangular) shape.
 - This configuration is also used for controlling balanced three-phase resistive loads.
 - It can be used in applications like industrial electric furnaces and kilns.
3. **FULL-WAVE BRIDGE CONFIGURATION:**
 - A full-wave bridge configuration consists of six SCRs arranged in a bridge topology.
 - This configuration provides excellent control for both balanced and unbalanced three-phase loads.
 - It is suitable for various industrial applications, including motor control, temperature regulation, and power factor correction.

4. **THREE-PHASE HALF-WAVE CONFIGURATION:**
 - In this configuration, only one SCR is used for each phase of the load, and it is triggered during only one half-cycle of each phase.
 - This configuration is simpler but less efficient than full-wave configurations.
 - It is used in applications where efficiency is not a primary concern, such as resistive heating elements.

5. **PULSE-WIDTH MODULATION (PWM) CONTROLLED CONFIGURATION:**
 - In some advanced applications, SCR controllers are combined with PWM techniques to precisely control power by varying the width of the output pulses.
 - This allows for fine control over the power delivered to the load and is used in applications requiring high precision, like motor drives.

6. **FEEDBACK-CONTROLLED THREE-PHASE SCR CONTROLLER:**
 - Similar to the single-phase feedback-controlled configuration, this approach uses feedback loops to measure load conditions and adjust the firing angles of the SCRs to maintain a desired setpoint in three-phase systems.
 - Used in applications like three-phase voltage regulators and motor drives.

7. **THREE-PHASE SYNCHRONOUS CONTROL:**
 - In this configuration, a controller is used to synchronize the firing angles of the three SCRs to maintain the load's voltage or power factor in synchronization with the supply voltage.
 - Commonly used in applications requiring power factor correction and precise voltage regulation.

The choice of SCR controller configuration for three-phase systems depends on the specific requirements of the application, including load characteristics, precision needs, efficiency considerations, and cost constraints. Additionally, safety measures and protective devices, such as fuses and overcurrent protection, should be implemented in SCR controllers to ensure safe and reliable operation.